

CLF EF SMOKE 3100 MANUAL

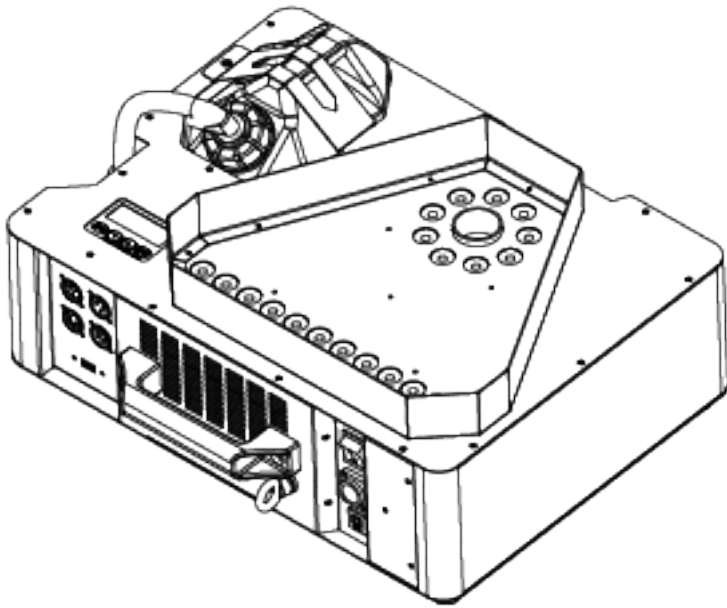
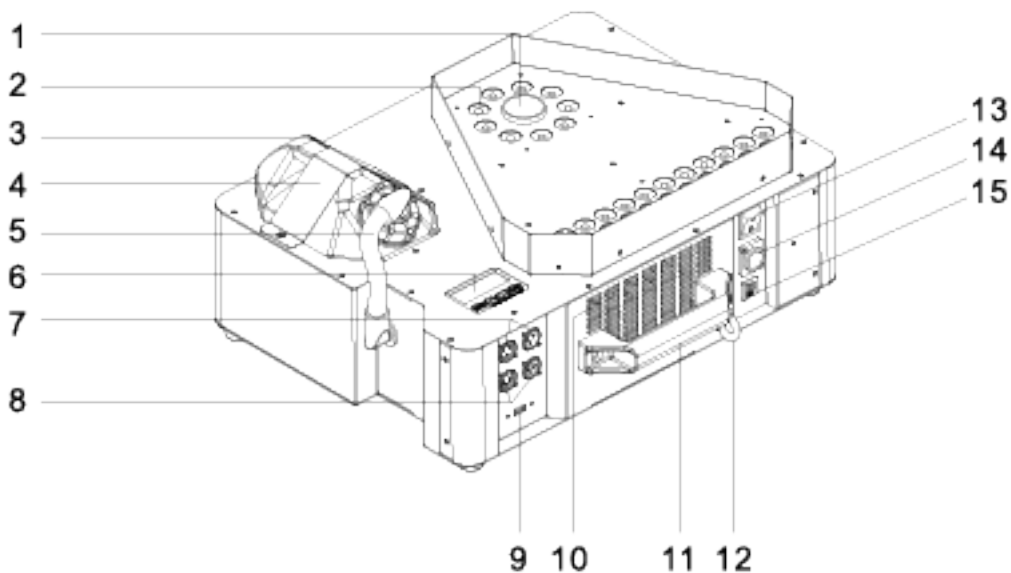

TABLE OF CONTENTS

Machine overview	3
Safety instruction	4
AC power	6
Data link	6
Physical installation	7
Operating instructions	7
Menu navigation	8
DMX channels	9
Maintenance	10
Specifications	11
Exploded view	12

MACHINE OVERVIEW



1. Nozzle
2. LED
3. 2.5L tank
4. Tank fixing plate
5. Fluid tube
6. LCD display
7. 3-pin DMX socket
8. 5-pin DMX socket
9. USB
10. Ventilation
11. Handle
12. Safety point
13. Power switch
14. PoweCON
15. Overload protection

SAFETY INSTRUCTION



WARNING!

Read the safety precautions in this section before installing, powering, operating or servicing this product

The following symbols are used to identify important safety information on the product and in this manual:



DANGER!
Safety hazard.
Risk of severe injury or death.



DANGER!
Hazardous voltage. Risk of lethal or severe electric shock.



WARNING!
Fire hazard.



WARNING!
LED light emission. Risk of eye injury.



WARNING!
Burn hazard. Hot surface. Do not touch.



WARNING!
Wear protective eyewear.



WARNING!
Refer to user manual.



USING FOR THE FIRST TIME

This product is for professional use only. It is not for household use.

This product presents risks of severe injury or death due to fire and burn hazards, electric shock and falls.

Read this manual before installing, powering or servicing the fixture, follow the safety precautions listed below and observe all warnings in this manual and printed on the fixture. If you have questions about how to operate the fixture safely, please contact your supplier.



PROTECTION FROM ELECTRIC SHOCK



- Disconnect the machine from AC power before removing or installing any cover or part and when not in use.
- Always ground (earth) the fixture electrically.
- Use only a source of AC power that complies with local building and electrical codes and has both overload and ground-fault (earth-fault) protection.
- Before using the machine check that all power distribution equipment and cables are in perfect condition and rated for the current requirements of all connected devices.
- Power input and throughput cables must be rated 20 A minimum, have three conductors 1.5 mm² (16 AWG) minimum conductor size and an outer cable diameter of 5 - 15 mm . Cables must be hard usage type (SJT or equivalent) and heat-resistant to 90° C minimum.
- Use only PowerCON® cable connectors to connect to power input sockets. Use only PowerCON® cable connectors to connect to power through put sockets.
- Isolate the machine from power immediately if the power plug or any seal, cover, cable, or other component is damaged, defective, deformed, wet or showing signs of overheating. Do not reapply power until repairs have been completed.



DO NOT EXPOSE THE FIXTURE TO RAIN OR MOISTURE

CLF EF Smoke 3100 has an IP20 rating, indoor use only.

SAFETY INSTRUCTION



PROTECTION FROM BURNS AND FIRE



- Do not operate the machine if the ambient temperature (T_a) exceeds 45°C.
- The exterior of the machine becomes hot during use. Avoid contact by persons and materials. Allow the machine to cool for at least 10 minutes before handling.
- Keep all combustible materials (e.g. fabric, wood, paper) at least 100 mm away from the nozzle
- Keep flammable materials well away from the machine
- Ensure that there is free and unobstructed airflow around the machine
- Do not place objects within 200 mm of the machine
- Do not attempt to bypass thermostatic switches or fuses.
- If you relay power from one machine to another using power throughput sockets, do not connect more than 1 machines in total to each other in an interconnected chain.
- Connect only other machines to fixture power throughput sockets. Do not connect any other type of device to these sockets.
- Do not connect any other type of device to these sockets.
- Do not stick filters, masks or other materials onto any optical component.
- Do not modify the machine in any way not described in this manual
- Do not connect machine to a dimmer



PROTECTION FROM INJURY



- Ensure that persons are not looking at the LEDs from within 3 meters when the product lights up suddenly. This can happen when power is applied, when the product receives a DMX signal, or when SERVICE menu items are selected.
- Fasten the fixture securely to a fixed surface or structure when in use. The fixture is not portable when installed.
- Ensure that any supporting structure and/or hardware used can hold at least 10 times the weight of all the devices they support.
- Allow enough clearance around the head to ensure that it cannot collide with an object or another fixture when it moves.
- Check that all external covers and rigging hardware are securely fastened.
- Block access below the work area and work from a stable platform whenever installing, servicing or moving the machine
- Do not operate the machine with missing or damaged covers, shields or any optical component.

AC POWER



POWER VOLTAGE

Check that the voltage range specified on the machine serial number label matches the local AC mains power voltage before applying power to the fixture. The machine accepts AC mains power at 100-240 V nominal, 50/60 Hz. Do not apply AC mains power to the machine at any other voltage than specified.



POWER CABLES

Power input and throughput cables must be rated 20 A minimum, have three conductors 1.5 mm² (16 AWG) minimum conductor size and an outer cable diameter of 5 - 15 mm. Cables must be hard usage type (SJT or equivalent) and heat-resistant to 90°C minimum. In the EU the cable must be HAR approved or equivalent. If you install a power plug on the power cable, install a grounding-type (earthed) plug that is rated 20 A minimum. Follow the plug manufacturer's instructions. Table 1 shows standard wire color-coding schemes and some possible pin identification schemes; if pins are not clearly identified, or if you have any doubts



Wire color (EU models)	Wire color (US models)	Conductor	Symbol	Screw (US)
Brown	Black	Live	L	Yellow or Brass
Blue	White	Neutral	N	Silver
Yellow / green	Green	Ground (earth)	 or 	Green

Table 1: Wire color-coding and power connections

DATA LINK

A DMX 512 data link is required in order to control a machine via DMX. The machine has 3 & 5-pin XLR connectors for DMX data input and output. The pin-out on all connectors is pin 1 = shield, pin 2 = cold (-), and pin 3 = hot (+) Pins 4 and 5 in the 5-pin XLR connectors are not used.

TIPS FOR RELIABLE DATA TRANSMISSION

To connect the machine to data:

1. Connect the DMX data output from the controller to the closest machine's male 3 & 5-pin XLR DMX input connector.
2. Connect the DMX output of the machine closest to the controller to the DMX input of the next machine and continue connecting machines output to input.

PHYSICAL INSTALLATION



Warning! The machine must be either fastened to a flat surface such as a stage or wall, or clamped to a truss or similar structure in any orientation using a rigging clamp.

Warning! At all times machine can cause injury or damage if it falls, attach an approved safety cable to one of the safety cable attachment points on the base (see “machine overview” on page 4).



Check that all surfaces more far away than a minimum of 200 mm. from the machine, that combustible materials (wood, fabric, paper, etc.) are minimum 100 mm. from the nozzle, that there is free airflow around the machine and that there are no flammable materials nearby.

FASTENING THE MACHINE TO A FLAT SURFACE

The machine can be fastened to a fixed flat surface that is oriented at any angle. Check that the surface can support at least 10 times the weight of all machines and equipment to be installed on it. Warning! The supporting surface must be flat otherwise the air vents in the base may be blocked, which will cause overheating. Fasten the machine securely. Do not place it on a surface or leave it where it can be moved or can fall over. Attach a securely anchored safety cable to the safety cable attachment point (see “machine overview” on page.

If the machine is installed in any location where it may fall and cause injury or damage if the primary attachment fails:

1. Block access under the work area. Working from a stable platform.
2. Secure the machine with a secondary attachment such as an approved safety cable that is rated for the weight of the machine using one of the attachment points at the edges of the base (see “machine overview” on page 4). Do not use any other part of the machine as a safety cable attachment point.

OPERATING INSTRUCTIONS

1. After checking that all the parts are intact and complete, position the machine on a flat surface.
2. Only use designated CLF Lighting smoke liquid. Machine can be harmed when using other fluids and warranty is expired.
3. Connecting the power cord. Before power on, make sure it is connected with the rated voltage.
4. Turn on the machine, it will immediately start heating up, the digital display will show “WARMING UP”.

MENU INSTRUCTION

1. MENU button: When it shows “HEAT”, press “menu” button to enter the page “ADDR”
2. UP button: Increase the relevant value of each page
3. DOWN button: Decrease the relevant value of each page
4. ENTER button: Enter or exit each page

WIRELESS CONTROLL

When the unit is powered on, and the wireless status is ON, the LCD display will show “wireless setup”. In such case, user can register the wireless remote by pressing any button for 1s on the remote. If the LCD display flickers twice, then it is matched with the unit successfully. One unit can match with 5 remotes at most. If user register the sixth one, then the memory for the first five remotes will be erased. Press ON button to run the unit or OFF button to stop it. When the machine is under wireless remote control, the haze output is the one set by VOLUME OUT. For example, if the VOLUME OUT is 1%, then it will be 1% when controlled by wireless remote. Press button A to run, release it to stop. The operation of B,C,D is same as button A.

Note:

1. When matching the wireless remote, please make sure the LCD display flicker twice. Then release the A button to match the wireless remote, Otherwise, it might fail.
2. If the wireless remote setup is OFF (i.e. LCD displays “Wireless Set OFF”), when the machine is powered on again, the LCD display will not show “wireless setup”.
3. Wireless remote control will void if the unit is connected to DMX.

MENU NAVIGATION

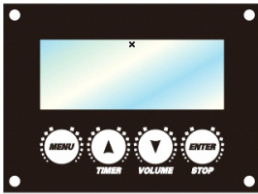

MENU:	Scroll through setting menu;
UP:	Increase, multiplex "TIMER" button;
DOWN:	Decrease, multiplex "VOLUME" button;
ENTER:	In/Out, multiplex "stop" button;

Press "MENU" button to switch different pages, 10 pages in total:

1. Ready To Fog: The machine is ready to work
2. Interval Set: To set the interval of timer mode , adjustable from 1~200s
3. Duration Set: To set the duration of timer mode , adjustable from 1~200s
4. Channel A from 0-10 Set the color when triggered by wireless remote controller button A
5. Channel B from 0-10 Set the color when triggered by wireless remote controller button B
6. Channel C from 0-10 Set the color when triggered by wireless remote controller button C
7. Channel D from 0-10 Set the color when triggered by wireless remote controller button D
8. DMX512 Address: The DMX address can be set up from 1 to 512
9. Wireless Set: To turn on/off the wireless function
10. Language: Select the language saved by "Enter"

When the machine is not working, press "Stop" to Exit. When the machine is working, press "Stop" to stop machine working and go back to home page. Press UP or DOWN to change the value in each setting page. At home page, press TIMER button to activate timer mode, LCD displays as below:

- Interval 10s: Interval countdown
- Duration 10s: Duration countdown

The two pages will display circularly when each countdown finish, "Interval" and "Duration" time could be set in page 2 and 3. At home page, press VOLUME button to activate volume mode, the machine starts to fog

At Channel A page, press ENTER button to LED color setting page. Press UP and DOWN to choose color. Press ENTER to save and exit the setting. There are total 11 LED color modes, which are "OFF", "Co1-Co9" (9 colors) and "random color changing (rand)" mode. The color setting of Channel A will be effected when press button A of the wireless controller.

1. When set to OFF, the LED would not light up.
2. 9 colors are as following:
 - Co 1: Red
 - Co 2: Green
 - Co 3: Blue
 - Co 4: Pink
 - Co 5: Purple
 - Co 6: Orange
 - Co 7: Yellow
 - Co 8: Sky blue
 - Co 9: White

After setting the color, the corresponding color will light up when output controlled by wireless remoter. When Random mode, the LED will change color randomly, the interval is 1s.

Note: When connected to DMX controller, the color setting from this page will be invalid, the LED color would be controlled by DMX controller

Wireless remote control button 1-4 trigger the options set in the color program CH-1-CH-4, respectively. DMX When connected DMX controller, the LCD shows DMX address setting page only, to easily set DMX address.

FLUID

This machine use electronic program to detect whether there is fluid inside tube or not, hence to protect the pump from being damaged when there is no fluid.

1. How to activate "low-fluid protection". When the and activate it, so when the internal inspection module check out there is no oil inside the tube but the machine is still working, then the machine will get into oil free protection 20s later by shutting the pump off. The digital display will keep flashing.
2. How to release "low-fluid protection". When the machine is under the protection of low fluid, after refilling the fluid, there are three ways to release the protection.
3. Keep pressing the one board red fog button until the fog liquid fill the tube completely, then the machine would exit low-fluid protection.
4. Under the wireless remote control, keep pressing any buttons until the fog liquid fill the tube completely, then the machine would exit low-fluid protection.
5. Under the DMX control, firstly push the slider of channel one to the value below 10(Fog OFF),then push the slider up to value above 10(Fog ON), the machine would exit low-fluid protection by doing so.

Note: When the machine is heating up. HEAT page is prior to ADDR and all the other pages. Without connecting with DMX, the digital display will back to page ADDR automatically.

DMX CHANNELS

Channel	Function	Value	Percentage	Remark
CH 1	FOG output	010 - 255	0 - 100%	000 - 009 = OFF
CH 2	Inner LED red output	010 - 255	0 - 100%	000 - 009 = OFF
CH 3	Inner LED green output	010 - 255	0 - 100%	000 - 009 = OFF
CH 4	Inner LED blue output	010 - 255	0 - 100%	000 - 009 = OFF
CH 5	Outer LED red output	010 - 255	0 - 100%	000 - 009 = OFF
CH 6	Outer LED green output	010 - 255	0 - 100%	000 - 009 = OFF
CH 7	Outer LED blue output	010 - 255	0 - 100%	000 - 009 = OFF
CH 8	Color Macro	010 - 255	0 - 100%	000 - 009 = OFF
CH 9	Color Macro speed	010 - 255	0 - 100%	000 - 009 = OFF
CH 10	LED strobe	010 - 255	0 - 100%	000 - 009 = OFF
CH 11	LED dimmer	010 - 255	0 - 100%	000 - 009 = OFF

MAINTENANCE

Oil injection trouble:

Refers to the fog fluid atomizing in the heater pipe of the machine is not good, heater temperature cannot be timely and effective transmit to the fog fluid, fog fluid cannot all atomization and lead to oil injection.

1. Using the low quality or counterfeit fog fluid, low quality fog fluid have more impurities, easy to adhere to the pipe wall and hindered temperature transmission result in incomplete atomization caused oil injection.
2. Using an incorrect fog fluid. Different fog fluid have different required atomization temperature. If you use the wrong fog fluid result in oil cannot fully atomization caused oil injection.(fig 1)

Heater blocking trouble:

Poor atomization oil injection is the early signs of heater block. Using poor quality fog fluid or not timely maintenance cleaning the fog machine for a long time. Inevitable will appear the terminal symptom of heater blocking.

1. heater blocked is because used inferior fog fluid or not maintenance for a long time. Have nothing to do with the quality of machine. Like a car with poor quality gasoline produce poor oil circuit failure or long-time no maintenance the car will inevitably appear bigger problems. (fig 2)

Solutions to these problems:

Fog machine heating pipes used for a long time and then the pipe wall will easily produce sediments (The more inferior fog fluid the more impurities thus lead to oil injection or blocked). All fog machines need regular maintenance (fog machine maintenance cycle for 1 to 2 months/time).

Specific maintenance method: after heating the 35% white vinegar plus 65% distilled water and then spray 10 to 15 times.

Conclusion:

As long as the fog machine with oil injection or heater blocking after using a period of time. It was caused by fog fluid quality or lack of maintenance, has nothing to do with the quality of the machine. Please use the original high quality fog fluid and timely maintain it, then it can be used for a long time

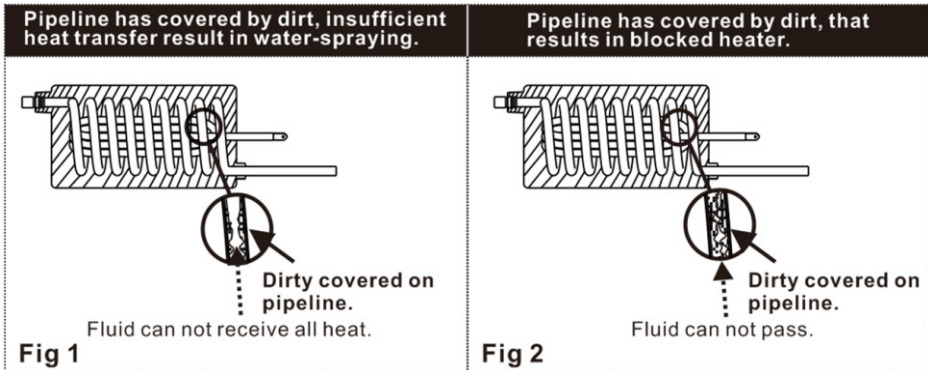

SPECIFICATIONS

Power	3100W
LED	LED bottom smoke: 9 PCS RGB LED top smoke: 23 PCS RGB
Voltage / frequency	AC100V - 240V - 50/60Hz
Fuse	15A/250V
Power consumption; all effects static, zero light output	<25W
AC power input	PowerCON
DMX data in/out	5 pin & 3 pin locking XLR
Netto weight	16kg
Size	475x401x205mm
Control	DMX & Wireless
Channel	11 channels
Output	54000CUFT/MIN (max 10m height and max 8 sec)
Settings and addressing	Control panel with backlit LED graphic display
Protocol	USITT DMX512-A & Wireless
Color	Black
Housing	High strenght die-casting aluminium and metal
Protection rating	IP20
Orientation	Up and downwards (when fuel tank is rotated)
Min. distance to combustable materials	100mm from machine
Min. distance to iluminated surfaces	200mm from machine
Wireless remote	4 button remote
Fluid consumption	3,7min/L
Fluid capacity	2,5L
Fluid brand	CLF Fog fluid
Heat up time	4 min
Max. ambient temperature (Ta max)	45°C

EXPLODED VIEW

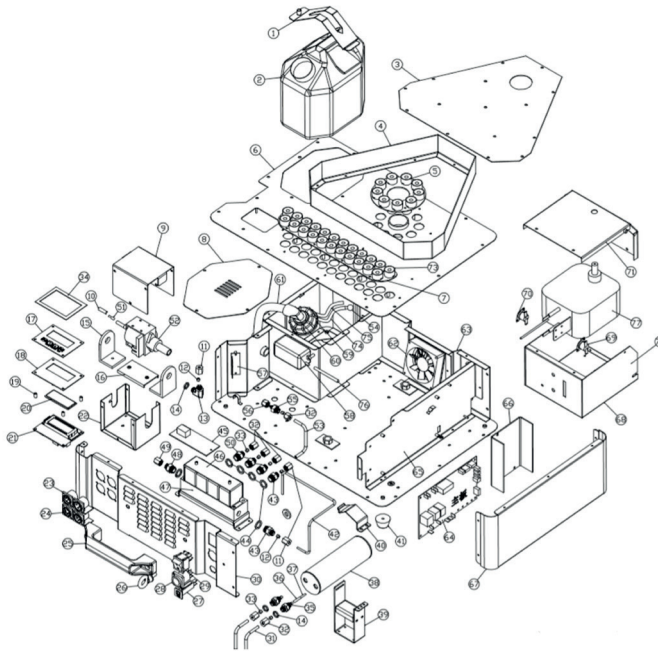

No.	Description	Part number CLF	No.	Description	Part number CLF
1	Bracket fluid container	CLF-70-190	40	Pressure tank bracket cover plate	CLF-70-217
2	Fluid container	CLF-70-163	41	Rubber foot	CLF-70-218
3	Transparent LED cover	CLF-70-191	42	Steel long pipe	CLF-70-219
4	LED top ring	CLF-70-192	43	Stainless connector solenoid valve copper line	CLF-70-220
5	LED board (ring)	CLF-70-193	44	Gasket	CLF-70-221
6	LED top cover	CLF-70-194	45	Driver board	CLF-70-222
7	LED board (line)	CLF-70-195	46	Driver board mounting bracket	CLF-70-223
8	Fluid container plate	CLF-70-156	47	Solenoid valve	CLF-70-224
9	Pump top cover	CLF-70-196	48	Copper connector	CLF-70-225
10	Fluid line pump	CLF-70-197	49	Copper cap solenoid valve fluid line	CLF-70-170
11	Copper cap fluid pump	CLF-70-175	50	Stainless steel joint	CLF-70-226
12	Copper meson fluid pump	CLF-70-198	51	Straight connector fluid line	CLF-70-103
13	Copper elbow adaptor fluid pump	CLF-70-199	52	Fluid pump	CLF-70-227
14	Gasket for copper elbow	CLF-70-201	53	Copper pipe	CLF-70-228
15	Rubber pump bracket	CLF-70-202	54	Fluid Filter	CLF-70-229
16	Support bracket for rubber bracket pump	CLF-70-203	55	Copper joints	CLF-70-230
17	Display sticker	CLF-70-015	56	Copper cap fluid line	CLF-70-089
18	LCD support plate	CLF-70-016	57	3-pin DMX PCB (male/female)	CLF-70-019
19	Plastic display support	CLF-70-017	58	Air pump	CLF-70-231
20	Display glass	CLF-70-084	59	Bracket fluid container	CLF-70-232
21	Display PCB	CLF-70-204	60	Elbow connector fluid line	CLF-70-164
22	Fluid pump bracket	CLF-70-205	61	Fluid line	CLF-70-165
23	3-pin DMX PCB (male/female)	CLF-70-019	62	Fan	CLF-70-233
24	5-pin DMX PCB (male/female)	CLF-70-009	63	Base bottom	CLF-70-234
25	Handle	CLF-70-206	64	Main PCB	CLF-70-235
26	Safety eye	CLF-70-004	65	Main PCB plate	CLF-70-236
27	Fuse	CLF-70-207	66	Power supply	CLF-70-152
28	Powercon output socket white	CLF-70-010	67	Back panel	CLF-70-237
29	Mains switch	CLF-70-148	68	Heater bottom cover	CLF-70-238
30	Front cover	CLF-70-208	69	Thermostat	CLF-70-168
31	Copper pipe	CLF-70-209	70	Thermostat manual resettable	CLF-70-178
32	Copper cap solenoid valve copper line	CLF-70-174	71	Heater top cover	CLF-70-239
33	Copper Ring	CLF-70-210	72	Complete heater core with metal housing	CLF-70-240
34	Display seal	CLF-70-211	73	Lens LED	CLF-70-134
35	Copper connector solenoid valve copper line	CLF-70-212	74	Fluid line In	CLF-70-241
36	Air line	CLF-70-213	75	Fluid line out	CLF-70-242
37	Steel pipe	CLF-70-214	76	Silicone Air pump tube	CLF-70-243
38	Pressure tank	CLF-70-215	77	Heater block	CLF-70-244
39	Pressure tank bracket	CLF-70-216			



CLF EF SMOKE 3100