

# TABLE OF CONTENTS

<b>Dimensions</b>	1
<b>Safety Information</b>	2
<b>Fixture overview</b>	4
<b>Introduction</b>	5
<b>AC power</b>	5
Power voltage	5
Power cables	6
Relaying power to other devices	6
<b>Data link</b>	6
Tips for reliable data transmission	6
<b>Physical installation</b>	7
Fastening the fixture to a flat surface	7
<b>Setup</b>	8
Control panel and menu navigation	8
DMX address setting	8
Control Mode	9
Static Color options	10
Auto Show	11
Master / Slave	11
<b>Personality</b>	11
Dimmer speed	11
Dimmer curve	11
Key-Lock	11
W-DMX	11
Calibration	11
Refresh rate	11
LCD brightness	11
DMX HOLD	11
<b>Dimmer mode</b>	12
<b>Information</b>	12
Software type	12
Usage time	12
Temperature	12
UID	12
<b>Factory reset</b>	12
<b>DMX protocols</b>	13
<b>Onboard control menus</b>	18
<b>Exploded view</b>	19
<b>Specifications</b>	20
<b>IP65</b>	21

# DIMENSIONS

ALL DIMENSIONS ARE IN MILLIMETERS

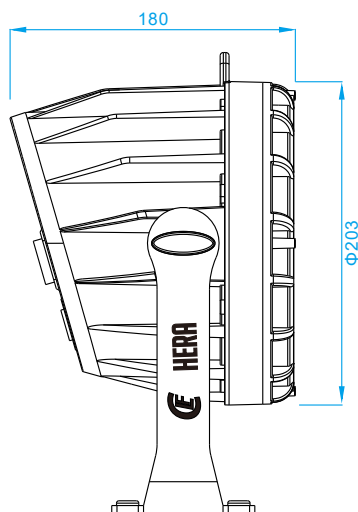
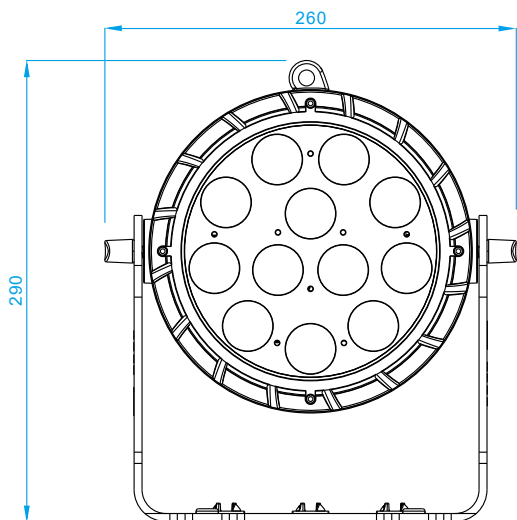
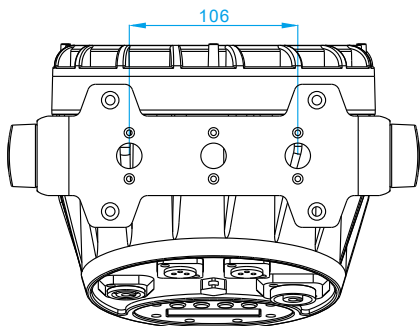

# SAFETY INFORMATION



## WARNING!

Read the safety precautions in this section before installing, powering, operating or servicing this product

The following symbols are used to identify important safety information on the product and in this manual:



**DANGER!**  
Safety hazard.  
Risk of severe injury or death.



**DANGER!**  
Hazardous voltage. Risk of lethal or severe electric shock.



**WARNING!**  
Fire hazard.



**WARNING!**  
LED light emission. Risk of eye injury.



**WARNING!**  
Burn hazard. Hot surface. Do not touch.



**WARNING!**  
Wear protective eyewear.



**WARNING!**  
Refer to user manual.



**Warning! Risk Group 3 (high risk) LED product according to EN 62471. Do not look into the beam at a distance of less than 3 meters from the front surface of the product. Do not view the light output with optical instruments or any device that may concentrate the beam.**

This product is for professional use only. It is not for household use.



This product presents risks of severe injury or death due to fire and burn hazards, electric shock and falls.

Read this manual before installing, powering or servicing the fixture, follow the safety precautions listed below and observe all warnings in this manual and printed on the fixture. If you have questions about how to operate the fixture safely, please contact your supplier.



### PROTECTION FROM ELECTRIC SHOCK

- Disconnect the fixture from AC power before removing or installing any cover or part and when not in use.
- Always ground (earth) the fixture electrically.
- Use only a source of AC power that complies with local building and electrical codes and has both overload and ground-fault (earth-fault) protection.
- Before using the fixture, check that all power distribution equipment and cables are in perfect condition and rated for the current requirements of all connected devices.
- Power input and through out cables must be rated 16A minimum, have three conductors 1.5 mm<sup>2</sup> (16 AWG) minimum conductor size and an outer cable diameter of 5 - 15 mm . Cables must be hard usage type (SJT or equivalent) and heat-resistant to 90° C minimum.
- Use only PowerCON TRUE 1<sup>®</sup> cable connectors to connect to power input sockets. Use only PowerCON TRUE 1<sup>®</sup> cable connectors to connect to power through put sockets.
- Isolate the fixture from power immediately if the power plug or any seal, cover, cable, or other component is damaged, defective, deformed, wet or showing signs of overheating. Do not reapply power until repairs have been completed.



## DO NOT EXPOSE THE FIXTURE TO RAIN OR MOISTURE

- Refer any service operation not described in this manual to a qualified technician.
- Socket outlets used to supply the fixture with power or external power switches must be located near the fixtures and easily accessible so that the fixtures can easily be disconnected from power.

## PROTECTION FROM BURNS AND FIRE



- The exterior of the fixture becomes hot during use. Avoid contact by persons and materials. Allow the fixture to cool for at least 10 minutes before handling.
- Keep all combustible materials (e.g. fabric, wood, paper) at least 100 mm away from the fixture.
- Keep flammable materials well away from the fixture.
- Ensure that there is free and unobstructed airflow around the fixture.



- Do not illuminate surfaces within 200 mm of the fixture.
- Do not attempt to bypass thermostatic switches or fuses.
- If you relay power from one fixture to another using power throughput sockets, do not connect more than ten the fixture in total to each other in an interconnected chain.
- Connect only other the fixture to fixture power throughput sockets. Do not connect any other type of device to these sockets.
- Do not connect any other type of device to these sockets.
- Do not stick filters, masks or other materials onto any optical component, besides the optional CLF Hera filters.
- Do not modify the fixture in any way not described in this manual.
- Do not use fixture on a dimmer.

## PROTECTION FROM INJURY



- Do not look continuously at LEDs from a distance of less than 3 meters from the front surface of the fixture without protective eyewear such as shade 4-5 welding goggles. At less than this distance, the LED emission can cause eye injury or irritation. At distances of 3 meters and above, light output is harmless to the naked eye provided that the eye's natural aversion response is not overcome.



- Do not look at LEDs with magnifiers, telescopes, binoculars or similar optical instruments that may concentrate the light output.
- Ensure that persons are not looking at the LEDs from within 3 meters when the product lights up suddenly. This can happen when power is applied, when the product receives a DMX signal, or when SERVICE menu items are selected.



- Fasten the fixture securely to a fixed surface or structure when in use.
- Ensure that any supporting structure and/or hardware used can hold at least 10 times the weight of all the devices they support.
- Allow enough clearance around the fixture to ensure that it cannot collide with an object or another fixture when it moves.
- Check that all external covers and rigging hardware are fastened securely.
- Block access below the work area and work from a stable platform whenever installing, servicing or moving the fixture.
- Do not operate the fixture with missing or damaged covers, shields or any optical component.

# FIXTURE OVERVIEW

5P DMX input  
3P DMX input (optional)  
# CLF-13-453

5P DMX output  
3P DMX output (optional)  
# CLF-13-454

AC mains power  
input

AC mains power  
throughput

Control buttons

LCD Display

Safety cable  
attachment point

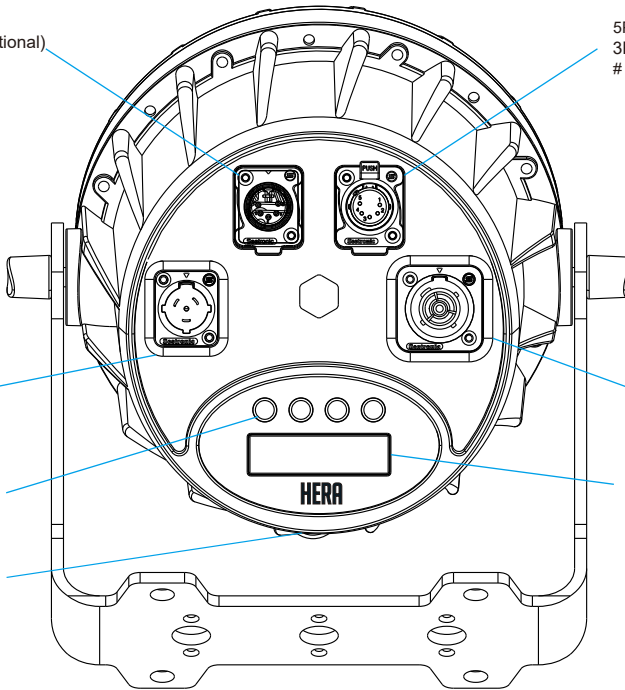

G Clamp with  
Quicklock # 875760  
(Optional)

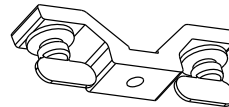
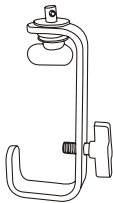

Omega bracket with  
Quicklock # 520114  
(Optional)

# INTRODUCTION

## OUTDOOR RGBWAP LED FIXTURE

### AFFORDABLE LIGHTING ESSENTIAL

- Unique bracket design
- Touring proof
- Smooth RGBWUUV color mixing
- Ip65 rating
- Silent operation
- Wireless DMX (Optional )
- Smooth projection
- Powercon true 1<sup>®</sup> in & out
- RDM ready

### USING FOR THE FIRST TIME



**Warning!** Read “Safety Information” on page 2 before installing, powering, operating or servicing the fixture. Before applying power to the fixture:

- Check that the local AC mains power source is within the fixture's power voltage and frequency ranges.
- See “Power cables and power plug” on page 6. Install a PowerCON TRUE 1<sup>®</sup> power input connector on a suitable power cable.

# AC POWER



**Warning!** Read “Safety Information” starting on page 2 before connecting the fixtures to AC mains power.

**Warning!** For protection from electric shock, the fixture must be grounded (earthed). The power distribution circuit must be equipped with a fuse or circuit breaker and ground-fault (earth-fault) protection.



**Warning!** Socket outlets or external power switches used to supply the fixture with power must be located near the fixture and easily accessible so that the fixtures can easily be disconnected from power.

**Important!** Do not insert or remove live PowerCON TRUE 1<sup>®</sup> connectors to apply or cut power, as this may cause arcing at the terminals that will damage the connectors.

**Important!** Do not use an external dimming system to supply power to the fixture, as this may cause damage to the fixture that is not covered by the product warranty.

The fixture can be hard-wired to a electrical installation if you want to install it permanently, or a power plug that is suitable for the local power outlets can be installed on the power cable.

### POWER VOLTAGE



**Warning!** Check that the voltage range specified on the fixtures serial number label matches the local AC mains power voltage before applying power to the fixture.

The fixtures accepts AC mains power at 100-240 V nominal, 50/60 Hz. Do not apply AC mains power to the fixture at any other voltage than specified.

## POWER CABLES

Power input and throughput cables must be rated 16A minimum, have three conductors 1.5 mm<sup>2</sup> (16 AWG) minimum conductor size and an outer cable diameter of 5 - 15 mm. Cables must be hard usage type (SJT or equivalent) and heat-resistant to 90°C minimum. In the EU the cable must be HAR approved or equivalent.

If you install a power plug on the power cable, install a grounding-type (earthed) plug that is rated 16A minimum. Follow the plug manufacturer's instructions. Table 1 shows standard wire color-coding schemes and some possible pin identification schemes; if pins are not clearly identified.



Wire Color (EU models)	Wire Color (US models)	Conductor	Symbol
Brown	Black	Live	L
Blue	White	Neutral	N
Yellow/Green	Green	Ground (earth)	 or 

Table 1 : Wire color-coding and power connections

## RELAYING POWER TO OTHER DEVICES

Warning! Do not connect more than ten fixtures in total to AC mains power in one interconnected chain. Power can be relayed to another device via the PowerCON TRUE 1<sup>®</sup> throughput socket.

If you daisy chain the fixtures in a chain so that they all draw AC mains power via the first fixture, certain points must be respected:

- A heavy duty, three-conductor, 16 AWG or 1.5 mm<sup>2</sup> cable with SJT or equivalent cable jacket must be used to connect the first fixture to AC mains power.
- PowerCON TRUE 1<sup>®</sup> connectors must be used to draw AC mains power from the fixtures power throughput sockets and yellow PowerCON TRUE 1<sup>®</sup> connectors must be used to supply power at the fixture's power input sockets.
- No matter what the AC mains power voltage is, do not connect more than ten the fixture in total ( including the first fixture) to AC mains power in one interconnected daisy chain using power input and through out connectors.

# DATA LINK

A DMX 512 data link is required in order to control a fixture via DMX. The fixture has 5-pin XLR connectors for DMX data input and output. The pin-out on all connectors is pin 1 = shield, pin 2 = cold (-), and pin 3 = hot (+) Pins 4 and 5 in the 5-pin XLR connectors are not used.

## TIPS FOR RELIABLE DATA TRANSMISSION

To connect the fixture to data:

1. Connect the DMX data output from the controller to the 5-pin XLR connector of the nearest fixture.
2. Connect the DMX output of the fixture closest to the controller to the DMX input of the next fixture and continue connecting fixtures output to input.



# PHYSICAL INSTALLATION

Warning! The fixture must be either fastened to a flat surface such as a stage or wall, or clamped to a truss or similar structure in any orientation using a rigging clamp.

Warning! If the fixture can cause injury or damage if it falls, attach an approved safety cable to one of the safety cable attachment points on the base (see "Fixture overview" on page 4).

Check that all surfaces to be illuminated are minimum 200 mm. from the fixture, that combustible materials (wood, fabric, paper, etc.) are minimum 100 mm. from the fixture, that there is free airflow around the fixture and that there are no flammable materials nearby.

## FASTENING THE FIXTURE TO A FLAT SURFACE

The fixture can be fastened to a fixed flat surface that is oriented at any angle. Check that the surface can support at least 10 times the weight of all fixtures and equipment to be installed on it.



Warning! The supporting surface must be hard and flat or air vents in the base may be blocked, which will cause overheating. Fasten the fixture securely. Do not stand it on a surface or leave it where it can be moved or can fall over. Attach a securely anchored safety cable to the safety cable attachment point (see "Fixture overview" on page 4) if the fixture is to be installed in any location where it may fall and cause injury or damage if the primary attachment fails.

1. Block access under the work area. Working from a stable platform, hang the fixture on the truss. Tighten the rigging clamp.
2. Secure the fixture against clamp failure with a secondary attachment such as an approved safety cable that is rated for the weight of the fixture using one of the attachment points at the edges of the base (see "Fixture overview" on page 4). Do not use any other part of the fixture as a safety cable attachment point.

# SETUP

Warning! Read "Safety Information" on page 2 before installing, powering, operating the fixture.

## CONTROL PANEL AND MENU NAVIGATION

The onboard control panel and backlit graphic display are used to set the fixture's DMX address, configure individual fixture settings (personality), read out data and execute service utilities. See "Onboard control menus" on page 17 for a complete list of menus and commands.

Using the control buttons

- To enter the menu select [MODE].
- Press [UP] and [DOWN] to scroll within a menu or adjust values.
- To enter a menu, select a function or apply a selection, press [ENTER].
- To escape a function or move back one level in the menu structure, press [MODE].
- Holding down the "UP" and "DOWN" button for more than 3 seconds, the MENU display will rotate 180°.



## DMX ADDRESS SETTING

The DMX address, also known as the start channel, is the first channel used to receive instructions from the controller. For independent control, each fixture must be assigned its to a separate channel .

The DMX address can be configured by using the DMX ADDRESS menu in the control panel. For setting the DMX address press [ENTER] before you can change the address.

- The main screen will show a 'dot' and the backlight will be switched off when a DMX signal is detected.
- The fixture is fully RDM ready. So when you are using a RDM ready console you can address the unit and read out its complete status. For RDM functions please refer to the ANSI/ESTA E1.20-2006 standard

## W-DMX CONTROL

Go to the W-DMX section in the main menu, press the button "UP" to switch off Wireless DMX or disconnect with all connected Transmitters.

Press the button "DOWN" to set the unit in the "ready to connect with all not connected transmitters" mode. If you press the mode button on the Wireless solution transmitter all the units in this mode will be connected.

If the unit is successfully connected in the home display the sign "▲ : V " appears. If the unit is not connected to a transmitter in the home display the sign "▲ : X ". If the unit is switched off in the home display the sign "▲ : OFF ".

- Holding the **MENU** and **ENTER** button for more than 3 seconds, the wireless board will reset.
- Do not use Wireless DMX and Wired DMX at the same time because it will give unwanted interference

## CONTROL MODE

DMX control mode is selected in the CONTROL MODE menu. The fixture has 9 DMX control modes:

	4ch	5ch	6ch	7ch	8ch	11ch	13ch
Dimmer		✓		✓	✓	✓	✓
RGBW	✓	✓	✓	✓	✓	✓	✓
A+UV			✓	✓	✓		✓
Strobe					✓	✓	✓
CCT						✓	✓
Macro color						✓	✓
Effect						✓	✓
Dimmer / Auto speed						✓	✓
Function set						✓	✓

	HSV	HSI
Hue	✓	✓
Saturation	✓	✓
Value	✓	
Intensity		✓

## STATIC COLOR OPTIONS

There are three options for static color:

### 1. FIXED COLOR

Several options from combined RGBW values. Use Up and Down to scroll through the options.

R = Red	RB = Red & Blue	BW = Red & White
G = Green	GB = Green & Blue	RGW = Red, Green & White
B = Blue	RGB = Red, Green & Blue	RBW = Red, Blue & White
W = White	RW = Red & White	GBW = Green, Blue & White
RG = Red & Green	GW = Green & White	RGBW = Red, Green, Blue & White

### 2. CCT

Easy color choice between 2500K (warm white) to 10000K (cold white)

2500K	7000K
3000K	8000K
4000K	9000K
5000K	10000K
6000K	

### 3. MANUAL COLOR

Mix your own color with each RGBWAP value separately.

Red	<000-255>	Dimmer Red
Green	<000-255>	Dimmer Green
Blue	<000-255>	Dimmer Blue
White	<000-255>	Dimmer White
Amber	<000-255>	Dimmer Amber
UV	<000-255>	Dimmer UV

## AUTO SHOW

The auto function gives 10 auto programs and 10 custom programs RGBW color combinations which are working without any DMX console. Hit [ENTER] to adjust the speed of the Auto program from 1-20.

1) Auto 1	Auto program 1	11) Program 1	pre-program 1
2) Auto 2	Auto program 2	12) Program 2	pre-program 2
3) Auto 3	Auto program 3	13) Program 3	pre-program 3
4) Auto 4	Auto program 4	14) Program 4	pre-program 4
5) Auto 5	Auto program 5	15) Program 5	pre-program 5
6) Auto 6	Auto program 6	16) Program 6	pre-program 6
7) Auto 7	Auto program 7	17) Program 7	pre-program 7
8) Auto 8	Auto program 8	18) Program 8	pre-program 8
9) Auto 9	Auto program 9	19) Program 9	pre-program 9
10) Auto 10	Auto program 1-10 cycle	20) Program 10	pre-program 10

## MASTER/SLAVE

You can choose between master or slave functioning. The chosen mode is visible in the homescreen. The fixture will automatically go to slave function when no DMX signal is offered.

# PERSONALITY

Here you can set all functions for the fixture.

Dimmer Speed	Normal / Smooth 1 / Smooth 2 / Smooth 3 / Smooth 4
Dimmer curve	linear / Square law / INV Square law / S- Curve / Special
KEY-Lock	Locks all the button functions. Standard unlocking password is (MODE+UP+MODE+DOWN+MODE+UP+MODE+DOWN+ENTER)
W-DMX	No
CALIBRATION	NO CALIBRATION = Color calibration mode off. MANUAL = Manual calibration mode, RGBW to white is custom calibration
Refresh rate	Controls the Flicker frequency of the fixture 600 1200 2400 4800
LCD brightness	Set the LCD display brightness(1-10)
DMX HOLD	DMX HOLD = The fixture will remember on last values when you disconnect DMX NO DMX HOLD = The fixture has no output when you disconnect DMX

# DIMMER MODE

provides five dimming options (see picture below):

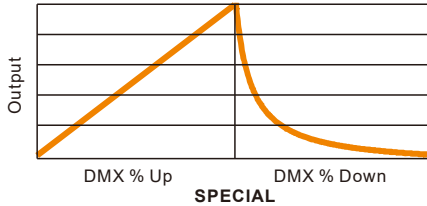
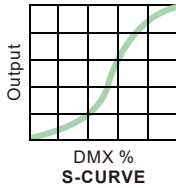
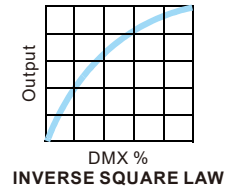
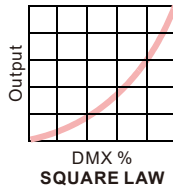
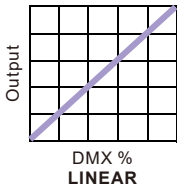

- **LINEAR** – the increase in light intensity appears to be linear as DMX value is increased.
- **SQUARE LAW** – light intensity control is finer at low levels and coarser at high levels.
- **INV Square law** – light intensity control is coarser at low levels and finer at high levels.
- **S-CURVE** – light intensity control is finer at low levels and high levels and coarser at medium levels.
- **Special** – the light intensity was linear increase with DMX value , and light intensity control is finer at low level with DMX values decrease , the dimmer speed will also has effect on it

Whichever **DIMMER CURVE** option you select, you can choose between **NORMAL** or **SMOOTH 1 / 2 / 3 / 4** dimming settings:

- **NORMAL** is the default setting. It gives a virtually instantaneous reaction when you dim from one intensity to another, but dimming slowly from one intensity to another may appear slightly uneven.
- The **SMOOTH 1 / 2 / 3 / 4** setting gives smoother dimming during slow changes in intensity, but it limits the speed of dimming changes slightly. This makes it ideal for slow, smooth dimming, but a short time-lag may be noticeable if you try to dim quickly from one intensity to another.

## INFORMATION

Software type	Shows software version (Vx.x)
Usage time	Use of time and use time reset (password)
Temperature	LED board current temperature
UID	Shows the unique ID for the RDM protocoll. <0x02E20002xxxx>

## FACTORY RESET

Resets the fixture to its factory default settings.  
Please reboot power before reset takes effect.

# DMX PROTOCOLS

HSV	Function	Value	Setting	Remark
1	Hue	000 - 255	0 - 100%	
2	Saturation	000 - 255	0 - 100%	
3	Value	000 - 255	0 - 100%	

**Note:** In HSV mode, Hue stands for the visible light, such as red, yellow, and cyan, etc. Saturation refers to the dominance of hue in the color; when saturation is at 100%, then the color is at its purest. Value is the color's brightness; when value is at 100%, then the color is at its brightest.

HSI	Function	Value	Setting	Remark
1	Hue	000 - 255	0 - 100%	
2	Saturation	000 - 255	0 - 100%	
3	Intensity	000 - 255	0 - 100%	

4 CH	Function	Value	Setting	Remark
1	Red	000 - 255	0 - 100%	
2	Green	000 - 255	0 - 100%	
3	Blue	000 - 255	0 - 100%	
4	White	000 - 255	0 - 100%	

5 CH	Function	Value	Setting	Remark
1	Dimmer	000 - 255	0 - 100%	
2	Red	000 - 255	0 - 100%	
3	Green	000 - 255	0 - 100%	
4	Blue	000 - 255	0 - 100%	
5	White	000 - 255	0 - 100%	

6 CH	Function	Value	Setting	Remark
1	Red	000 - 255	0 - 100%	
2	Green	000 - 255	0 - 100%	
3	Blue	000 - 255	0 - 100%	
4	White	000 - 255	0 - 100%	
5	Amber	000 - 255	0 - 100%	
6	UV	000 - 255	0 - 100%	

# DMX PROTOCOLS

7 CH	Function	Value	Setting	Remark
1	Dimmer	000 - 255	0 - 100%	
2	Red	000 - 255	0 - 100%	
3	Green	000 - 255	0 - 100%	
4	Blue	000 - 255	0 - 100%	
5	White	000 - 255	0 - 100%	
6	Amber	000 - 255	0 - 100%	
7	UV	000 - 255	0 - 100%	

8 CH	Function	Value	Setting	Remark
1	Dimmer	000 - 255	0 - 100%	
2	Red	000 - 255	0 - 100%	
3	Green	000 - 255	0 - 100%	
4	Blue	000 - 255	0 - 100%	
5	White	000 - 255	0 - 100%	
6	Amber	000 - 255	0 - 100%	
7	UV	000 - 255	0 - 100%	
8	Shutter	000 - 019	No function	
		020 - 024	Shutter open	
		025 - 064	Strobe 1 (fast → slow)	
		065 - 069	Shutter open	
		070 - 084	Strobe 2: opening pulse (fast → slow)	
		085 - 089	Shutter open	
		090 - 104	Strobe 3: closing pulse (fast → slow)	
		105 - 109	Shutter open	
		110 - 124	Strobe 4: random strobe (fast → slow)	
		125 - 129	Shutter open	
		130 - 144	Strobe 5: random opening pulse (fast → slow)	
		145 - 149	Shutter open	
		150 - 164	Strobe 6: random closing pulse (fast → slow)	
		165 - 169	Shutter open	
		170 - 184	Strobe 7: burst pulse (fast → slow)	
185 - 189	Shutter open			
190 - 204	Strobe 8: random burst pulse (fast → slow)			
205 - 209	Shutter open			
210 - 224	Strobe 9: sine wave (fast → slow)			
225 - 229	Shutter open			
230 - 244	Strobe 10: burst (fast → slow)			
245 - 255	Shutter open			



11 CH	Function	Value	Setting	Remark
1	Dimmer	000 - 255	0 - 100%	
2	Red	000 - 255	0 - 100%	
3	Green	000 - 255	0 - 100%	
4	Blue	000 - 255	0 - 100%	
5	White	000 - 255	0 - 100%	
6	Shutter	000 - 019	No function	
		020 - 024	Shutter open	
		025 - 064	Strobe 1 (fast → slow)	
		065 - 069	Shutter open	
		070 - 084	Strobe 2: opening pulse (fast → slow)	
		085 - 089	Shutter open	
		090 - 104	Strobe 3: closing pulse (fast → slow)	
		105 - 109	Shutter open	
		110 - 124	Strobe 4: random strobe (fast → slow)	
		125 - 129	Shutter open	
		130 - 144	Strobe 5: random opening pulse (fast → slow)	
		145 - 149	Shutter open	
		150 - 164	Strobe 6: random closing pulse (fast → slow)	
		165 - 169	Shutter open	
170 - 184	Strobe 7: burst pulse (fast → slow)			
185 - 189	Shutter open			
190 - 204	Strobe 8: random burst pulse (fast → slow)			
205 - 209	Shutter open			
210 - 224	Strobe 9: sine wave (fast → slow)			
225 - 229	Shutter open			
230 - 244	Strobe 10: burst (fast → slow)			
245 - 255	Shutter open			
7	CCT	000 - 009	No function	
		010 - 255	10000K - 2500K	
8	Color wheel	000 - 009	No Function	
		010 - 255	Color wheel rotation effect	
9	Auto program	000 - 009	No function	
		010 - 019	Auto program 1	
		020 - 029	Auto program 2	
		.....	.....	
		100 - 109	Auto program 10 (AUTO 1-10 cycle)	
		110 - 119	Custom program 1	
120 - 129	Custom program 2			
...	.....			
200 - 255	Custom program 10			
10	Speed	000	No function	
		1 - 255	AUTO Speed or Dimmer Speed	
11	Fixture control settings	000 - 094	No function	<sup>1</sup> , value must be held for 3 seconds to activate.
		095 - 099	Manual calibration output mode <sup>1</sup>	
		100 - 104	Raw color output mode <sup>1</sup>	
		105 - 109	No function	
		110 - 114	Normal dimming, speed of changes unrestricted <sup>1</sup>	
		115 - 119	No function	
		120 - 124	Smooth dimming, speed of changes restricted slightly <sup>1</sup>	
		125 - 129	No function	
		130 - 134	600 Hz Refresh rate <sup>1</sup>	
		135 - 139	1200Hz Refresh rate <sup>1</sup>	
		140 - 144	2400Hz Refresh rate <sup>1</sup>	
		145 - 149	4800Hz Refresh rate <sup>1</sup>	
		150 - 154	No Function	
		155 - 159	WDMX - ON <sup>1</sup>	
		160 - 164	No Function	
		165 - 169	WDMX - OFF <sup>1</sup>	
		170 - 174	No Function	
175 - 179	WDMX - RESET <sup>1</sup>			
180 - 249	No Function			
250 - 255	illuminate display			

13 CH	Function	Value	Setting	Remark
1	Dimmer	000 - 255	0 - 100%	
2	Red	000 - 255	0 - 100%	
3	Green	000 - 255	0 - 100%	
4	Blue	000 - 255	0 - 100%	
5	White	000 - 255	0 - 100%	
6	Amber	000 - 255	0 - 100%	
7	UV	000 - 255	0 - 100%	
8	Shutter	000 - 019	No function	
		020 - 024	Shutter open	
		025 - 064	Strobe 1 (fast → slow)	
		065 - 069	Shutter open	
		070 - 084	Strobe 2: opening pulse (fast → slow)	
		085 - 089	Shutter open	
		090 - 104	Strobe 3: closing pulse (fast → slow)	
		105 - 109	Shutter open	
		110 - 124	Strobe 4: random strobe (fast → slow)	
		125 - 129	Shutter open	
		130 - 144	Strobe 5: random opening pulse (fast → slow)	
		145 - 149	Shutter open	
		150 - 164	Strobe 6: random closing pulse (fast → slow)	
		165 - 169	Shutter open	
170 - 184	Strobe 7: burst pulse (fast → slow)			
185 - 189	Shutter open			
190 - 204	Strobe 8: random burst pulse (fast → slow)			
205 - 209	Shutter open			
210 - 224	Strobe 9: sine wave (fast → slow)			
225 - 229	Shutter open			
230 - 244	Strobe 10: burst (fast → slow)			
245 - 255	Shutter open			
9	CCT	000 - 009	No function	
		010 - 255	10000K - 2500K	
10	Color wheel	000 - 004	No Function	
		005 - 255	Color wheel rotation effect	
11	Auto program	000 - 009	No function	
		010 - 019	Auto program 1	
		020 - 029	Auto program 2	
		.....	.....	
		100 - 109	Auto program 10 (AUTO 1-10 cycle)	
		110 - 119	Custom program 1	
		120 - 129	Custom program 2	
... 200 - 255	..... Custom program 10			
12	Speed	000	No function	
		1 - 255	AUTO Speed or Dimmer Speed	
13	Fixture control settings	000 - 094	No function	<sup>1</sup> , value must be held for 3 seconds to activate.
		095 - 099	Manual calibration output mode <sup>1</sup>	
		100 - 104	Raw color output mode <sup>1</sup>	
		105 - 109	No function	
		110 - 114	Normal dimming, speed of changes unrestricted <sup>1</sup>	
		115 - 119	No function	
		120 - 124	Smooth dimming, speed of changes restricted slightly <sup>1</sup>	
		125 - 129	No function	
		130 - 134	600 Hz Refresh rate <sup>1</sup>	
		135 - 139	1200Hz Refresh rate <sup>1</sup>	
		140 - 144	2400Hz Refresh rate <sup>1</sup>	
		145 - 149	4800Hz Refresh rate <sup>1</sup>	
		150 - 154	No Function	
		155 - 159	WDMX - ON <sup>1</sup>	
		160 - 164	No Function	
		165 - 169	WDMX - OFF <sup>1</sup>	
		170 - 174	No Function	
175 - 179	WDMX - RESET <sup>1</sup>			
180 - 249	No Function			
250 - 255	illuminate display			

# ONBOARD CONTROL MENUS

NO.	Main Menu	Menu level 2	Menu level 3	Remark
1	DMX ADDRESS	<001>		Default 001
		4CH	1. Red, 2.Green, 3.Blue, 4.White	
		5CH	1. Dimmer, 2.Red, 3.Green, 4.Blue, 5.White,	
		6CH	1.Red, 2. Green, 3.Blue,4. White, 5. Amber, 6. UV	
		7CH	1. Dimmer, 2.Red, 3.Green, 4. Blue, 5.White, 6.Amber, 7.UV	
		8CH	1. Dimmer, 2.Red, 3.Green, 4.Blue, 5.White, 6.Amber, 7.UV, 8.Strobe	
2	CONTROL MODE			Default : 13CH
		11CH	1. Dimmer , 2.Red , 3.Green , 4.Blue , 5.White 6.Strobe , 7.CCT , 8.Macro color , 9.Effect , 10.Speed , 11.Function set	
		13CH	1. Dimmer , 2.Red , 3.Green , 4.Blue , 5.White 6.Amber, 7.UV, 8.Strobe , 9.CCT , 10.Macro color , 11.Effect , 12.Speed , 13.Function set	
		HSV	1. Hue 2.Saturation 3.Value	
		HSI	1. Hue 2.Saturation 3.Intensity	
		Dimmer Speed	Normal	Default : Normal
			Smooth 1	
			Smooth 2	
			Smooth 3	
			Smooth 4	
		Dimmer curve	linear	Default : linear
			Square law	
			INV Square law	
			S- Curve	
			Special	
3	PERSONALITY	Key-Lock	ON/OFF	Default : OFF
			ON	
		W-DMX	OFF	Default : ON
			RESET	
		Calibration	No Calibration	Default : NO CALIBRATION
			Manual	
			Red (0-255)	
			Green (0-255)	
			Blue (0-255)	
		Refresh rate	600/1200/2400/4800	Default : 600
		LCD brightness	Level(1 - 10)	
		DMX HOLD	DMX HOLD	DMX HOLD
			NO DMX HOLD	

# ONBOARD CONTROL MENUS

NO.	Main Menu	Menu level 2	Menu level 3	Remark
4	STATIC COLOR	Fixed color	R, G, B, W, A, UV, AUV, RG, RB, GB, RGB, RW, GW, BW, RGW, RBW, GBW, RGBW, RA, GA, BA, WA, RGA, RBA, GBA, RGBA, RWA, GWA, BWA, RGWA, RBWA, GBWA, RGBWA, RUV, GUV, BUV, WUV, RGUV, RBUV, GBUV, RGBUV, RWUV, GWUV, BWUV, RGWUV, RBWUV, GBWUV, RGBWUV, RAUV, GAUV, BAUV, WAUV, RGAUV, RBAUV, GBAUV, RGBAUUV, RWAUV, GWAUV, BWAUV, RGWAUV, RBWAUV, GBWAUV, RGBWAUV	Default : RGBWAUV
		CCT	2500K/3000K/4000K/5000K/6000K/7000K /8000 / 9000K / 10000K	Default : 6000K
		Manual color	Dimmer (0-255) Red (0-255) Green (0-255) Blue (0-255) White (0-255) Amber (0-255) UV (0-255) Strobe (0-20)	Default : Dimmer:255 , Red:255 , Green:255 Blue:255 , White:255, Amber:255, UV:255, Strobe:0
5	AUTO	AUTO (1 - 10) Programe (1-10)	Speed 0 - 20	Default : AUTO 1
6	EDITOR	Programe (01 - 10)	Scene (01 - 30)	Red (0-255) Green (0-255) Blue (0-255) White (0-255) Amber (0-255) UV (0-255) Strobe (0-20) Time (0-255) Fade (0-255) Programe 10 has 90 Scenes
7	INFO	Software type Usage time Temperature UID	VX.XX TOTAL Xxxx hours RESET XXX°C 0x02E2000xxxxx	Use time reset (password)
8	FACTORY RESET	LOAD		

# EXPLODED VIEW

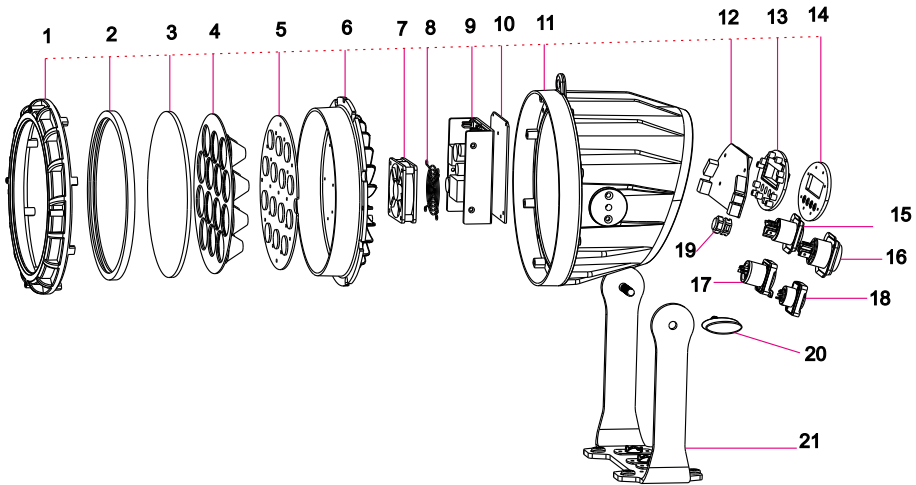

NO.	Description	Part Number
1	Front cover ring	CLF-14-003
2	Rubber glass ring	CLF-14-010
3	Tempered front glass	CLF-14-013
4	Lens kit	CLF-17-002
5	LED board	CLF-17-006
6	LED board radiator	CLF-14-002
7	Fan	CLF-14-016
8	Fan cover	CLF-14-017
9	Power supply	CLF-14-015
10	Power supply support bracket	CLF-14-007
11	Case body	CLF-14-001
12	Display board	CLF-17-005
13	Display sticker	CLF-17-004
14	Acrylic display support	CLF-14-012
15	PowerCON TRUE1 input socket	CLF-14-027
16	PowerCON TRUE1 output socket	CLF-14-028
17	DMX 5 pin male chassis part waterproof	CLF-14-032
18	DMX 5 pin female chassis part waterproof	CLF-14-031
19	Valve	CLF-14-023
20	Knob for bracket	CLF-14-014
21	Bracket	CLF-17-003

# SPECIFICATIONS

## Physical

Length	260mm
Width	180mm
Height	290mm
Weight	3.8 kg without accessories

## Dynamic Effects

beam angle	30°
------------	-----

## Optics

Light source	12 pcs high-power LEDs (RGBWAUV)
--------------	----------------------------------

## Control and Programming

Control	DMX512-A
DMX channels	4 / 5 / 6 / 7 / 8 / 11 / 13 / HSV / HSI
Setting and addressing	Control panel with backlit LCD graphic display
Protocol	RDM, USITT DMX512-A

## Control and Programming

Color	Black
Housing	High strength die-casting aluminum
Protection rating	IP 65 ( If rubbers covers are place correctly when connectors are not used )

## Installation

Orientation	Any
Minimum distance to combustible materials	100 mm. from fixture
Minimum distance to illuminated surfaces	200 mm. from fixture

## Connections

AC power input	PowerCON TRUE 1 <sup>®</sup> input socket
AC power throughput	PowerCON TRUE 1 <sup>®</sup> output socket
DMX data in/out	5 pin locking XLR (3 pin optional with # CLF-13-453 & CLF-13-454)

## Electrical

AC power	100-240 V nominal, 50/60 Hz
Maximum total power consumption	105 W
Power supply unit	Auto-ranging electronic switch mode
Power consumption, all effects static, zero light output	<15 W

## Power consumption

120 V, 60 Hz	105 W, PF * 0.986
240 V, 50 Hz	110 W, PF * 0.856

\* PF = power factor. Measurements made at nominal voltage with all LEDs at full intensity. Allow for a deviation of +/- 10%.

## Cooling

	Passive
Maximum ambient temperature (Ta max.)	40° C
Minimum ambient temperature (Ta min.)	-20° C
Total heat dissipation (calculated, +/- 10%)	820 BTU/hr.

# OUTDOOR IP-RATED FIXTURES

CLF products are applied to official classified IP norm levels. For this product the IP rate is IP65 when using the covers for the chassis parts. IP65 means according classified norm: shielded against dust and pressurized water from any side. Typical use for outdoor rated stage events with normal weather acceptance. So no heavy rain, because then the water pressure over exceeds the IP norm.

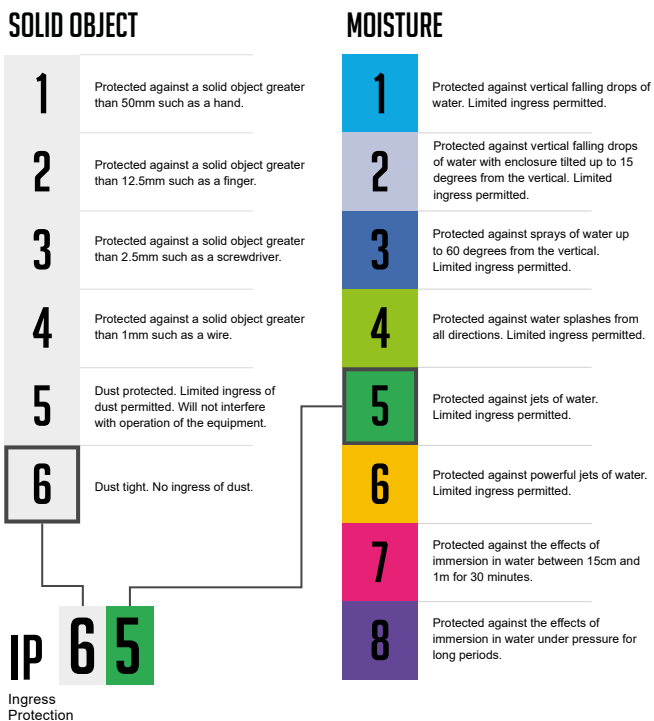

## CONDENSATION/MOISTURE INSIDE HOUSING

Because of high humidity levels during production condensation can occur inside the housing. This is mostly visible on the coldest parts of the fixture, like the front glass or display. To prevent this problem we work with special conditioned areas for outdoor fixtures. Because of the breathing air valves it is still possible to get humidity inside the fixture. This will evaporate slowly. Do not put wet fixtures in a flightcase, this will help humidity enter the fixture.

## FIXTURES TEMPERATURE SPECIFICATION

Make sure the fixture is used within its working temperature range. Outside this range we cannot guarantee correct operation.

## TEMPORARY USAGE:

Stage event equipment is designed with temporary use in mind. Our product purpose is for theatre, festival, (disco) clubs and indoor & outdoor concerts. Long term use is possible but keep in mind that it can bring damage to aging materials and affect the coated surface (i.e. stainless steel). Rubber sealings will be negatively affected after long-term UV exposure and should be checked by qualified service technicians over time.

Tighten screws too hard will also affect the IP-rating.





# HERA



**CLFLIGHTING**

[WWW.CLF-LIGHTING.COM](http://WWW.CLF-LIGHTING.COM)