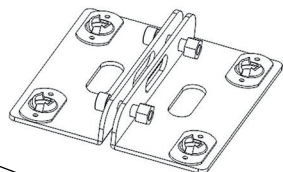
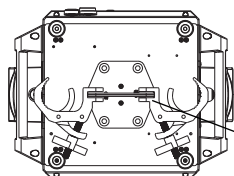

TABLE OF CONTENTS

Dimensions	1
Safety Instruction	2
Fixture overview	4
Introduction	5
AC Power	5
Power voltage	5
Power cables	6
Relaying power to other devices	6
Data link	6
Tips for reliable data transmission	6
Physical installation	7
Fastening the fixture to a flat surface	7
Outdoor IP-rated fixtures	8
Condensation/moisture inside housing	8
Fixtures temperature specification	8
Setup	9
Control panel and menu navigation	9
DMX address setting	9
Onboard control menus	10
DMX protocol	15
Gobo overview	22
Photometrics	23
Circuit connection diagram	24
Specifications	25

DIMENSIONS

ALL DIMENSIONS ARE IN MILLIMETERS



OPTIONAL HANGING BRACKET
ART. NO. 160022

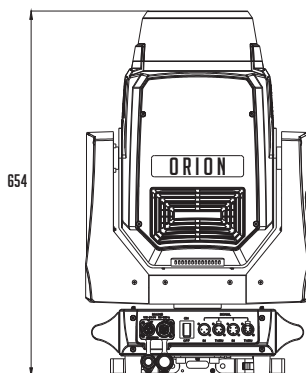
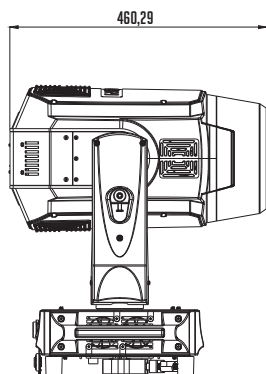
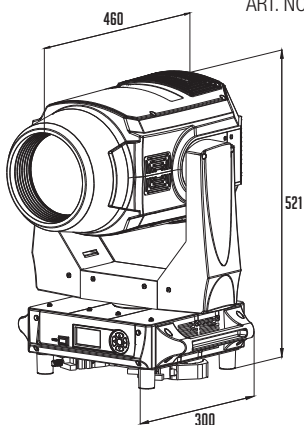
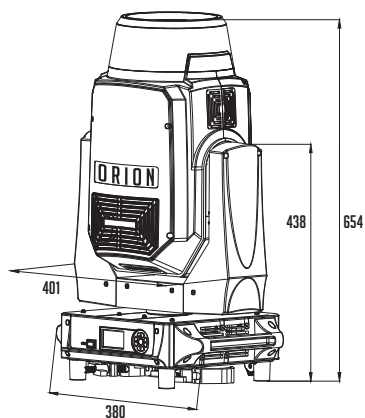

SAFETY INSTRUCTION



WARNING!

Read the safety precautions in this section before installing, powering, operating or servicing this product.

The following symbols are used to identify important safety information on the product and in this manual:



DANGER!
Safety hazard.
Risk of severe injury or death.



DANGER!
Hazardous voltage. Risk of lethal or severe electric shock.



WARNING!
Fire hazard.



WARNING!
Burn hazard. Hot surface. Do not touch.



WARNING!
Wear protective eyewear.



WARNING!
Refer to user manual.



This product is for professional use only. It is not for household use.

This product presents risks of severe injury or death due to fire and burn hazards, electric shock and falls.

Read this manual before installing, powering or servicing the fixture, follow the safety precautions listed below and observe all warnings in this manual and printed on the fixture. If you have questions about how to operate the fixture safely, please contact your supplier.



PROTECTION FROM ELECTRIC SHOCK



- Disconnect the fixture from AC power before removing or installing any cover or part and when not in use.
- Always ground (earth) the fixture electrically.
- Use only a source of AC power that complies with local building and electrical codes and has both overload and ground-fault (earth-fault) protection.
- Before using the fixture, check that all power distribution equipment and cables are in perfect condition and rated for the current requirements of all connected devices.
- Power input and throughput cables must be rated 20 A minimum, have three conductors 1.5 mm² (16 AWG) minimum conductor size and an outer cable diameter of 5 - 15 mm. Cables must be hard usage type (SJT or equivalent) and heat-resistant to 90° C minimum.
- Use only PowerCON TRUE 1 ® cable connectors to connect to power input sockets. Use only PowerCON TRUE 1 ® cable connectors to connect to power through put sockets.
- Isolate the fixture from power immediately if the power plug or any seal, cover, cable, or other component is damaged, defective, deformed, wet or showing signs of overheating. Do not reapply power until repairs have been completed.
- Refer any service operation not described in this manual to a qualified technician.
- Socket outlets used to supply fixture fixtures with power or external power switches must be located near the fixtures and easily accessible so that the fixtures can easily be disconnected from power.

PROTECTION FROM BURNS AND FIRE



- The exterior of the fixture becomes hot during use. Avoid contact by persons and materials. Allow the fixture to cool for at least 5 minutes before handling.
- Keep all combustible materials (e.g. fabric, wood, paper) at least 1 metres away from the fixture.
- Keep flammable materials well away from the fixture.
- Ensure that there is free and unobstructed airflow around the fixture.



- Do not illuminate surfaces within 12 metres of the fixture.
- Do not attempt to bypass thermostatic switches or fuses.
- If you relay power from one fixture to another using power throughput sockets, do not connect more than ten fixture fixtures in total to each other in an interconnected chain.
- Connect only other fixture fixtures to fixture power throughput sockets.
- Do not connect any other type of device to these sockets.
- Do not stick filters, masks or other materials onto any optical component.
- Do not modify the fixture in any way not described in this manual.

PROTECTION FROM INJURY



- Fasten the fixture securely to a fixed surface or structure when in use. The fixture is not portable when installed.
- Ensure that any supporting structure and/or hardware used can hold at least 10 times the weight of all the devices they support.
- Allow enough clearance around the head to ensure that it cannot collide with an object or another fixture when it moves.



- Check that all external covers and rigging hardware are securely fastened.
- Block access below the work area and work from a stable platform whenever installing, servicing or moving the fixture.
- Do not operate the fixture with missing or damaged covers, shields or any optical component.

FIXTURE OVERVIEW

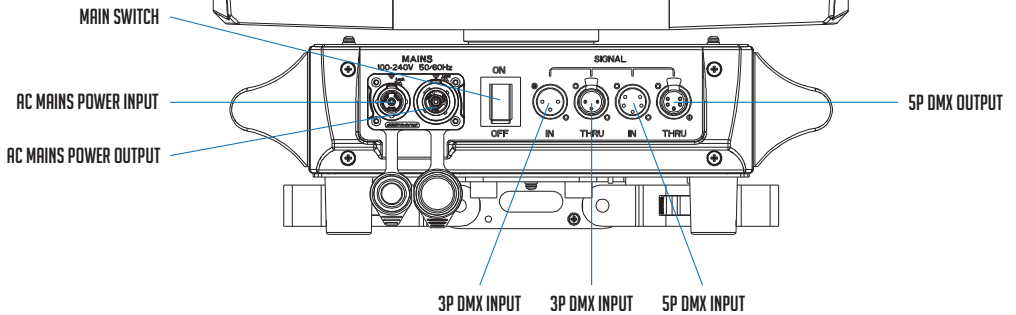
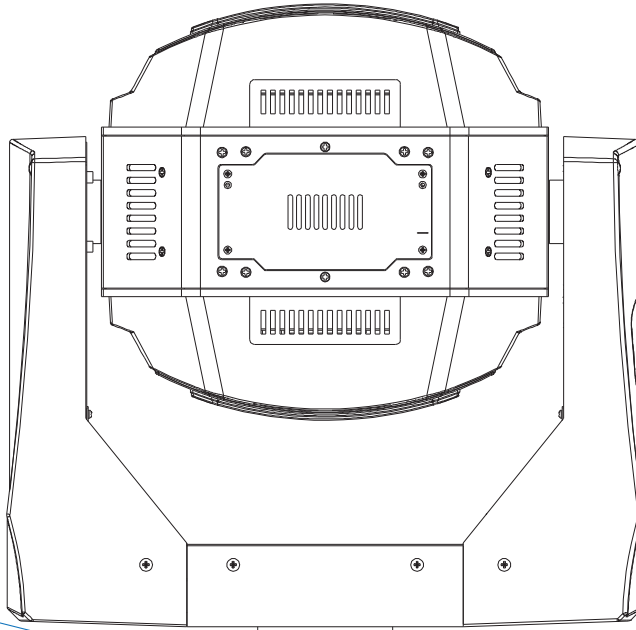

INTRODUCTION

FEATURE PACKED HYBRID LUMINAIRE

- CMY Color Mixing System
- Fixed Color Wheel
- 2 Gobo Wheels
- 3 + 1 Double Wheel Prisms
- 2 Level Frost Effect
- Zoom 2° - 42°
- Effect wheel

USING FOR THE FIRST TIME

Warning! Read “Safety Information” before installing, powering, operating or servicing the fixture. Before applying power to the fixture:

Check that the local AC mains power source is within the fixture’s power voltage and frequency ranges.

See “Power cables and power plug” on page 6. Install a PowerCON TRUE 1 @ power input connector power cable.

AC POWER



Warning! Read “Safety Information” starting on before connecting the fixtures to AC mains power.

Warning! For protection from electric shock, the fixture must be grounded (earthed). The power distribution circuit must be equipped with a fuse or circuit breaker and ground-fault (earth-fault) protection.

Warning! Socket outlets or external power switches used to supply the fixture with power must be located near the fixture and easily accessible so that the fixtures can easily be disconnected from power.



Important! Do not insert or remove live PowerCON TRUE 1 @ connectors to apply or cut power, as this may cause arcing at the terminals that will damage the connectors.

Important! Do not use an external dimming system to supply power to the fixture, as this may cause damage to the fixture that is not covered by the product warranty.

The fixture can be hard-wired to an electrical installation if you want to install it permanently, or a power plug that is suitable for the local power outlets can be installed on the power cable.



POWER VOLTAGE

Warning! Check that the voltage range specified on the fixture serial number label matches the local AC mains power voltage before applying power to the fixture.

The fixtures accepts AC mains power at 100-240 V nominal, 50/60 Hz. Do not apply AC mains power to the fixture at any other voltage than specified.

POWER CABLES

Power input and throughput cables must be rated 16A minimum, have three conductors 1.5 mm² (16 AWG) minimum conductor size and an outer cable diameter of 5 - 15 mm. Cables must be hard usage type (SJT or equivalent) and heat-resistant to 90°C minimum. In the EU the cable must be HAR approved or equivalent.

If you install a power plug on the power cable, install a grounding-type (earthed) plug that is rated 16A minimum. Follow the plug manufacturer's instructions. Table 1 shows standard wire color-coding schemes and some possible pin identification schemes; if pins are not clearly identified.



Wire Color (EU models)	Wire Color (US models)	Conductor	Symbol
Brown	Black	Live	L
Blue	White	Neutral	N
Yellow/Green	Green	Ground (earth)	 or 

Table 1 : Wire color-coding and power connections

RELAYING POWER TO OTHER DEVICES

Warning! Do not connect more than five fixtures in total to AC mains power in one interconnected chain. Power can be relayed to another device via the PowerCON TRUE 1 Ⓢ throughput socket.

If you daisy chain the fixtures in a chain so that they all draw AC mains power via the first fixture, certain points must be respected:

A heavy duty, three-conductor, 16 AWG or 1.5 mm² cable with SJT or equivalent cable jacket must be used to connect the first fixture to AC mains power.

- PowerCON TRUE 1 Ⓢ connectors must be used to draw AC mains power from the fixtures power throughput sockets and yellow PowerCON TRUE 1 Ⓢ connectors must be used to supply power at the fixture's power input sockets.
- No matter what the AC mains power voltage is, do not connect more than the fixture in total (including the first fixture) to AC mains power in one interconnected daisy chain using power input and through out connectors.

DATA LINK

A DMX 512 data link is required in order to control a fixture via DMX. The fixture has 5-pin XLR connectors for DMX data input and output. The pin-out on all connectors is pin 1 = shield, pin 2 = cold (-), and pin 3 = hot (+) Pins 4 and 5 in the 5-pin XLR connectors are not used.

TIPS FOR RELIABLE DATA TRANSMISSION

To connect the fixture to data:

1. Connect the DMX data output from the controller to the 5-pin XLR connector of the nearest fixture.
2. Connect the DMX output of the fixture closest to the controller to the DMX input of the next fixture and continue connecting fixtures output to input.

PHYSICAL INSTALLATION



Warning! The fixture must be either fastened to a flat surface such as a stage or wall, or clamped to a truss or similar structure in any orientation using a rigging clamp.

Warning! If the fixture can cause injury or damage if it falls, attach an approved safety cable to one of the safety cable attachment points on the base (see "Fixture overview").

Check that all surfaces to be illuminated are minimum 12 metres. from the fixture, that combustible materials (wood, fabric, paper, etc.) are minimum 1 metres. from the fixture, that there is free airflow around the fixture and that there are no flammable materials nearby.

FASTENING THE FIXTURE TO A FLAT SURFACE

The fixture can be fastened to a fixed flat surface that is oriented at any angle. Check that the surface can support at least 10 times the weight of all fixtures and equipment to be installed on it.



Warning! The supporting surface must be hard and flat or cooling may be blocked, which will cause overheating. Fasten the fixture securely. Do not stand it on a surface or leave it where it can be moved or can fall over. Attach a securely anchored safety cable to the safety cable attachment point (see "Fixture overview") if the fixture is to be installed in any location where it may fall and cause injury or damage if the primary attachment fails.

1. Block access under the work area. Working from a stable platform, hang the fixture on the truss with the arrow on the base towards the area to be illuminated. Tighten the rigging clamp.
2. Secure the fixture against clamp failure with a secondary attachment such as an approved safety cable that is rated for the weight of the fixture using one of the attachment points at the edges of the base (see "Fixture overview"). Do not use any other part of the fixture as a safety cable attachment point.

OUTDOOR IP-RATED FIXTURES

CLF products are applied to official classified IP norm levels. For this product the IP rate is IP65 when using the covers for the chassis parts. IP65 means according classified norm: shielded against dust and pressurized water from any side. Typical use for outdoor rated stage events with normal weather acceptance. So no heavy rain, because then the water pressure over exceeds the IP norm.

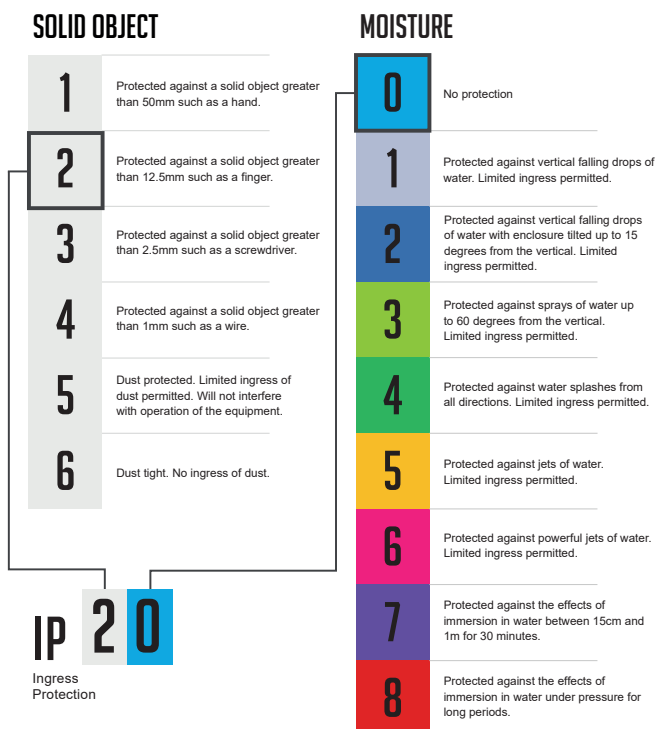

CONDENSATION/MOISTURE INSIDE HOUSING

Because of high humidity levels during production condensation can occur inside the housing. This is mostly visible on the coldest parts of the fixture, like the front glass or display. To prevent this problem we work with special conditioned areas for outdoor fixtures. Because of the breathing air valves it is still possible to get humidity inside the fixture. This will evaporate slowly. Do not put wet fixtures in a flightcase, this will help humidity enter the fixture.

FIXTURES TEMPERATURE SPECIFICATION

Make sure the fixture is used within its working temperature range. Outside this range we cannot guarantee correct operation.

TEMPORARY USAGE:

Stage event equipment is designed with temporary use in mind. Our product purpose is for theatre, festival, (disco) clubs and indoor & outdoor concerts. Long term use is possible but keep in mind that it can bring damage to aging materials and affect the coated surface (i.e. stainless steel). Rubber sealings will be negatively affected after long-term UV exposure and should be checked by qualified service technicians over time.

Tighten screws too hard will also affect the IP-rating.

SETUP

Warning! Read "Safety Information" before installing, powering, operating the fixture.

CONTROL PANEL AND MENU NAVIGATION

The onboard control panel and backlit graphic display are used to set the fixture's DMX address, configure individual fixture settings (personality), read out data and execute service utilities. See "Onboard control menus" for a complete list of menus and commands.

Using the control buttons

- To enter the menu select [ENTER].
- Press [UP], [DOWN], [LEFT] AND [RIGHT] to scroll within a menu or adjust values.
- To enter a menu, select a function or apply a selection, press [ENTER].
- To escape a function or move back one level in the menu structure, press [LEFT].

DMX ADDRESS SETTING

The DMX address, also known as the start channel, is the first channel used to receive instructions from the controller. For independent control, each fixture must be assigned its to a separate channel. The DMX address can be configured by using the DMX ADDRESS menu in the control panel. For setting the DMX address press [ENTER] before you can change the address.

- NO DMX: Display flashes and shows 'DMX: Fail'.
- DMX: Display backlight goes off and shows 'DMX: OK'.
- The fixture is fully RDM ready. So when you are using a RDM ready console you can address the unit and read out its complete status. For RDM functions please refer to the ANSI/ESTA E1.20-2006 standard

ONBOARD CONTROL MENUS

NO.	Main menu	Menu level 2	Menu level 3	Remark
1	DMX Address	001 - 512		
		Total Time	Power on: *** H Lamp on: *** H	
		Temperature	E-ballast: **,* Tempboard: **,*	
		RDM UID		
		MOTOR UID		
			1.U-Fan 1:00.0V 2.Mid-Fan :00.0V 3.L_Fan3&4:00.0V 4.L_Fan2:00.0V 5.L_Fan1:0000R 6.L_Fan 1:0000R 7.L_Fan 2:0000R 8.L_Fan 3:0000R 9.L_Fan 4:0000R 10.GoboFAN:0000R 11.U-Fan1:0000R 12.U-Fan2:0000R	
		Fan speed / Voltage		
2	Information			
		DMX Live	1.Pan *** 2.Pan Fine *** 3.Tilt *** 4.Tilt Fine *** 5.P/T Speed *** 6.Functions*** 7.Cyan *** 8.Magenta *** 9.Yellow *** 10.ColorWheel *** 11.Color Fine *** 12.Effect *** 13.Effect Rot *** 14.Static Gob *** 15.Rot Gobo *** 16.Gobo Rot *** 17.Prism 1 *** 18.Prism1 Rot *** 19.Prism 2 *** 20.Prism2 Rot ***	

NO.	Main menu	Menu level 2	Menu level 3	Remark	
2	Information	DMX Live	21.PrismMacro ***		
			22.Macro Rot ***		
			23.Frost ***		
			24.Zoom ***		
			25.Zoom Fine ***		
			26.Focus ***		
			27.Focus Fine ***		
			28.Focus 2 ***		
			29.AutoFocus ***		
			30.Shutter ***		
			31.Dimmer ***		
			32.DimmerFine ***		
			33.Hotspot ***		
		System version	XY: V*. **		
	Color: V*. **				
	Zoom: V*. **				
	Prism: V*. **				
	Display: V*. **				
	Return(ESC)				
3	Personal	Auto lamp on	OFF		
			ON		
		P/T invert	Pan invert	OFF	
				ON	
			Tilt invert	OFF	
				ON	
			Return(ESC)		
		CRI	Standard CRI		
			High CRI		
		Display	Backlight	Always on	
				Auto off (15s)	
			Rotate	Normal	
				Rotate 180	
			Backlight blink	ON	
		OFF			
	Return(ESC)				
	Return(ESC)				

NO.	Main menu	Menu level 2	Menu level 3	Remark
4	Manual Control	Channel control	1.Pan ***	
			2.Pan Fine ***	
			3.Tilt ***	
			4.Tilt Fine ***	
			5.P/T Speed ***	
			6.Functions***	
			7.Cyan ***	
			8.Magenta ***	
			9.Yellow ***	
			10.ColorWheel ***	
			11.Color Fine ***	
			12.Effect ***	
			13.Effect Rot ***	
			14.Static Gob ***	
			15.Rot Gobo ***	
			16.Gobo Rot ***	
			17.Prism 1 ***	
			18.Prism1 Rot ***	
			19.Prism 2 ***	
			20.Prism2 Rot ***	
			21.PrismMacro ***	
			22.Macro Rot ***	
			23.Frost ***	
			24.Zoom ***	
			25.Zoom Fine ***	
			26.Focus ***	
			27.Focus Fine ***	
			28.Focus 2 ***	
			29.AutoFocus ***	
			30.Shutter ***	
			31.Dimmer ***	
			32.DimmerFine ***	
			33.Hotspot ***	
			Return(ESC)	

NO.	Main menu	Menu level 2	Menu level 3	Remark
4	Manual Control	Reset	System reset	
			Pan/Tilt reset	
			Gobo reset	
			Color reset	
			Dimmer reset	
			Zoom reset	
			Effect reset	
			Return(ESC)	
		Return(ESC)		
			Error list	
	Clean error	Keep List		
		Empty List		
5	Service	Calibration 000 - 255	Pan	
			Tilt	
			Dimmer	
			Effect	
			Focus	
			Zoom	
			Color	
			Stat Gobo	
			Frost 1	
			Frost 2	
			Rot Gobo	
			Prism 1	
		Prism 2		
		Cyan		
		Magenta		
		Yellow		
		CRI		
		Hotspot		
		Return(ESC)		
			Factory	Load default
	Reset timers	Reset fixture hours: 4286		
		Reset lamp hours: 4288		
	Developer			
		Firmware update		
		Return (ESC)		
	Return (ESC)			

NO.	Main menu	Menu level 2	Menu level 3	Remark
5	Lamp	Off On		
6	Test	Test P/T Test effect Test all Return(ESC)	STEP *** STEP *** STEP ***	
7	Rotate display	Normal Rotate 180		

DMX PROTOCOL

CHANNEL	FUNCTION	VALUE	SETTING	REMARK
1	Pan	0-255	Pan	
2	Pan Fine	0-255	Pan Fine	
3	Tilt	0-255	Tilt	
4	Tilt fine	0-255	Tilt fine	
5	P/T speed	0	Standard mode (0=default)	
		0-255	Speed from max. to min.	
6	Special functions	0-9	Reserved (0=default)	
		10-14	Reserved	
		15-19	Reserved	
		20-24	LCD display On	
		25-29	LCD display Off	
		30-34	High CRI(CRI=90+)	
		35-39	Standard CRI(CRI=80)	
		40-44	Reserved	
		45-49	Reserved	
		50-54	Reserved	
		55-59	Reserved	
		60-64	Fans mode: Auto	
		65-69	Fans mode: High	
		70-74	Reserved	
		75-79	Reserved	
		80-84	Reserved	
		85-89	Reserved	
		90-94	Reserved	
		95-99	Reserved	
		100-101	Reserved	
102-103	Reserved			
104-105	Reserved			
106-107	Reserved			
108-119	Reserved			
120-124	Reserved			
125-129	Reserved			
130 - 139	Lamp On			
140 - 149	Pan/Tilt reset			
150 - 159	Color system reset			

CHANNEL	FUNCTION	VALUE	SETTING	REMARK
6	Special functions	160 - 169	Gobo wheels reset	
		170 - 179	Dimmer/Shutter reset	
		180 - 189	Zoom/focus/frost/prism wheels reset	
		190 - 199	Effect wheel reset	
		200 - 209	Total reset	
		210 - 229	Reserved	
		230 - 239	Lamp Off	
		240 - 244	Reserved	
		245 - 249	Reserved	
		250 - 255	Reserved	
7	Cyan	0 - 255	0 - 100%	
8	Magenta	0 - 255	0 - 100%	
9	Yellow	0 - 255	0 - 100%	
10	Color wheel	0	Open/white (0=default)	
		1-127	Index color	
		128-129	Open	
		130-134	Deep Red	
		135-138	Orange	
		139-143	Light blue	
		144-147	Green	
		148-152	lime	
		153-157	lavender	
		158-161	Pink	
		162-166	Yellow	
		167-171	Purple	
		172-176	Blue	
		177-180	CTO 2700K	
		181-185	CTO 3200K	
		186-189	UV (Congo blue)	
		190 - 215	Color scroll CW fast to slow	
216 - 217	No rotation			
218 - 243	Color scroll CCW slow to fast			
250 - 255	Random color selection from fast to slow			

CHANNEL	FUNCTION	VALUE	SETTING	REMARK
11	Color fine wheel	0 - 255	Fine positioning (0=default)	
12	Effect wheel	0-39	No function (0=default)	
		40-127	Index	
		128-170	Ramping from open to full position (max--->min. speed)	
		171-213	Ramping from open to half position (max. --->min. speed)	
		214-255	Ramp. from half position to full position (max. --->min. speed)	
13	Effect wheel rotate	0	No rotation	
		1-127	Forwards rotation from fast to slow	
		128	No rotation (128=default)	
		129-255	Backwards rotation from slow to fast	
14	Static Gobo Wheel	0-9	Open index	
		10-15	Gobo 1 index	
		16-21	Gobo 2 index	
		22-27	Gobo 3 index	
		28-33	Gobo 4 index	
		34-39	Gobo 5 index	
		40-45	Gobo 6 index	
		46-51	Gobo 7 index	
		52-57	Gobo 8 index	
		58-63	Gobo 9 index	
		64-69	Gobo 10 index	
		70-75	Gobo 11 index	
		76-81	Gobo 12 index	
		82-87	Gobo 13 index	
		88-95	Open shake slow to fast	
		96-103	Gobo 1shake slow to fast	
		104-111	Gobo 2 shake slow to fast	
112-119	Gobo 3 shake slow to fast			
120-127	Gobo 4 shake slow to fast			
128-135	Gobo 5 shake slow to fast			
136-143	Gobo 6 shake slow to fast			
144-151	Gobo 7 shake slow to fast			
152-159	Gobo 8 shake slow to fast			

CHANNEL	FUNCTION	VALUE	SETTING	REMARK
14	Static Gobo Wheel	160-167	Gobo 9 shake slow to fast	
		168-175	Gobo 10 shake slow to fast	
		176-183	Gobo 11 shake slow to fast	
		184-191	Gobo 12 shake slow to fast	
		192-199	Gobo 13 shake slow to fast	
		200-201	Open/hole	
		202-222	Gobo scroll CW from fast to slow	
		229-249	Gobo scroll CCW from slow to fast	
		250-255	Auto random gobo selection from fast to slow	
15	Rotating gobo wheel	0	Open index	
		1-4	Hole index	
		5-16	Gobo 1 index	
		17-28	Gobo 2 index	
		29-40	Gobo 3 index	
		41-52	Gobo 4 index	
		53-64	Gobo 5 index	
		65-76	Gobo 6 index	
		77-88	Gobo 7 index	
		89-100	Gobo 8 index	
		101-112	Gobo 9 index	
		113-124	Gobo 1 shake slow to fast	
		125-136	Gobo 2 shake slow to fast	
		137-148	Gobo 3 shake slow to fast	
		149-160	Gobo 4 shake slow to fast	
		161-172	Gobo 5 shake slow to fast	
		173-184	Gobo 6 shake slow to fast	
185-196	Gobo 7 shake slow to fast			
197-208	Gobo 8 shake slow to fast			
209-220	Gobo 9 shake slow to fast			
250-255	Random gobo fast to slow			

CHANNEL	FUNCTION	VALUE	SETTING	REMARK
16	Rotating gobo, wheel indexing and rotation	0-127	Gobo indexing	
		0	No rotation	
		128-187	gobo rotation CW from fast to slow	
		188-195	No rotation	
		196-255	Gobo rotation CCW slow to fast	
17	Prism wheel 1	0-3	Open position/hole (0=default)	
		4-15	Prism 1 - Linear index	
		16-27	Prism 2 - 4-facet index	
		28-39	Prism 3 - 8-facet index	
		40-51	Prism 1 - Linear facet rotate	
		52-63	Prism 2 - 4-facet facet rotate	
		64-255	Prism 3 - 8-facet facet rotate	
18	Prism wheel 1 indexing / rotating	0 - 255	Prism 1 indexing	
		0	No rotation	
		1 - 127	CW prism rotation from fast to slow	
		128	No rotation (128=default)	
		129-255	CCW prism rotation from slow to fast	
19	Prism wheel 2	0-3	Open position/hole (0=default)	
		4-15	Prism - 8-facet 18° circular	
		16-27	Prism - 8-facet 18° circular	
		28-255	Raw DMX	
20	Prism wheel 2 indexing / rotating	0-255	Prism indexing	
		0	No rotation	
		1-127	CCW prism rotation from fast to slow	
		128	No rotation (128=default)	
		129-255	CW prism rotation from slow to fast	
21	Prism macro	0-3	Open position/hole (0=default)	
		4-14	Prism macro Index 1	
		15-25	Prism macro Index 2	
		26-36	Prism macro Index 3	
		37-47	Prism macro Index 4	
		48-58	Prism macro Index 5	
		59-69	Prism macro Index 6	
		70-80	Prism macro Index 7	
		81-91	Prism macro rotation 1	
		92-102	Prism macro rotation 2	
		103-113	Prism macro rotation 3	
		114-124	Prism macro rotation 4	

CHANNEL	FUNCTION	VALUE	SETTING	REMARK
21	Prism macro	125-135	Prism macro rotation 5	
		136-146	Prism macro rotation 6	
		147-157	Prism macro rotation 7	
		158-168	Prism macro rotation 8	
		169-179	Prism macro rotation 9	
		180-190	Prism macro rotation 10	
22	Prism macro indexing / rotating	0 - 255	Pattern indexing	
		0	No rotation	
		1-127	CW rotation from fast to slow	
		128	No rotation (128=default)	
		129-255	CCW rotation from slow to fast	
23	Frost	0	Open (0=default)	
		1-50	Light Frost from 0% to 100%	
		51-53	100% Light Frost	
		54-63	Pulse closing from slow to fast	
		64-73	Pulse opening from fast to slow	
		74-83	Ramping from fast to slow	
		84-86	Open	
		87-136	Medium Frost from 0% to 100%	
		137-139	100% Medium Frost	
		140-149	Pulse closing from slow to fast	
		150-159	Pulse opening from fast to slow	
		160-169	Ramping from fast to slow	
		170-172	Open	
		173-222	Medium Frost from 0% to 100% (Light Frost inserted)	
		223-225	100% Medium Frost (Light Frost inserted)	
		226-235	Pulse closing from slow to fast (both frosts together)	
236-245	Pulse opening from fast to slow (both frosts together)			
246-255	Ramping from fast to slow (both frosts together)			
24	Zoom	0 - 255	Zoom from max. to min.beam angle (128=default)	
25	Zoom fine	0 - 255	Fine zooming (0=default)	
26	Focus	0 - 255		
27	Focus fine	0 - 255	Fine focusing (0=default)	
28	Offset	0-255		

CHANNEL	DMX	PERCENTAGE	FUNCTION
29	Auto focus select	0-15	Autofocus Off
		16-55	10 metres
		56-95	15 metres
		96-135	20 metres
		136-175	30 metres
		176-215	40 metres
		216-255	50 metres
30	Shutter	0 - 31	Shutter closed
		32 - 63	Shutter open
		64 - 95	Strobe-effect from slow to fast
		96 - 127	Shutter open
		128 - 143	Opening pulse in sequences from slow to fast
		144 - 159	Closing pulse in sequences from fast to slow
		160 - 191	Shutter open
		192 - 223	Random strobe-effect from slow to fast
224 - 255	Shutter open, Full lamp power		
31	Dimmer	0 - 255	Dimmer intensity from 0% to 100% (0=default)
32	Dimmer fine	0 - 255	Fine dimming (0=default)
33	Hotspot	0-127	Hotspot
		128-255	No hotspot

GOBO OVERVIEW

1



(Effect disk)

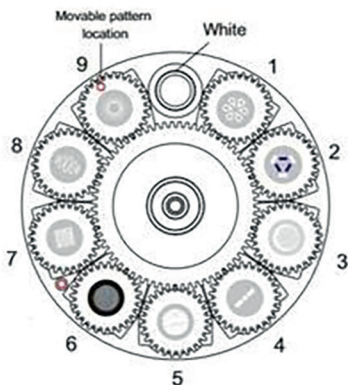

Rotating gobo wheel
(please refer to the actual material)

2

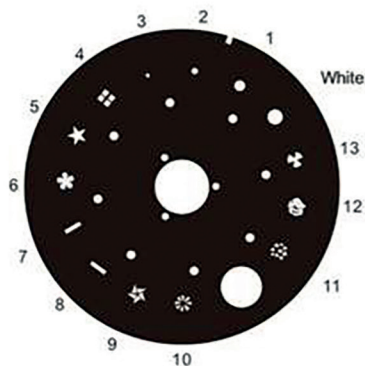

Static gobo wheel
(please refer to the actual material)



Color wheel
(please refer to the actual material)

PHOTOMETRICS

Orion distance, spot diameter and illumination diagram (beam mode)

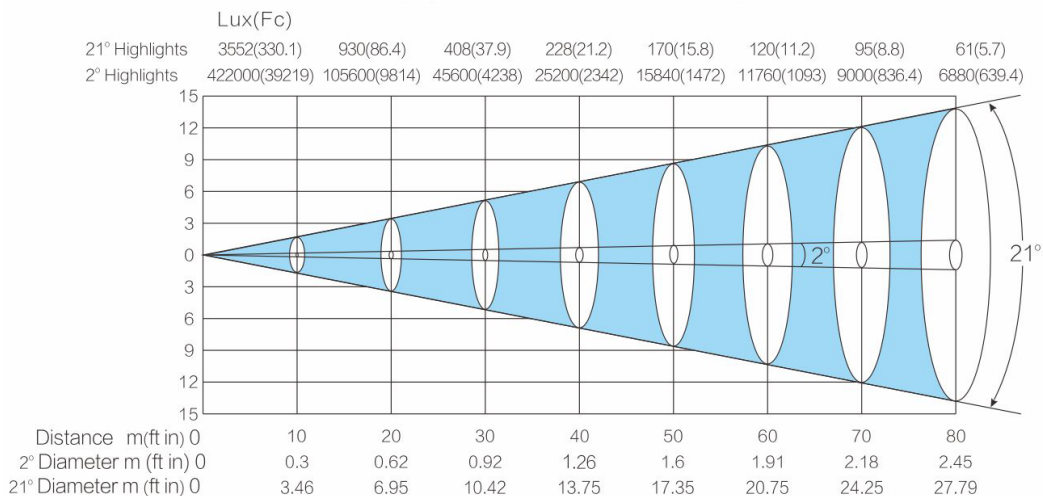

Orion distance, spot diameter and illumination diagram (spot mode)

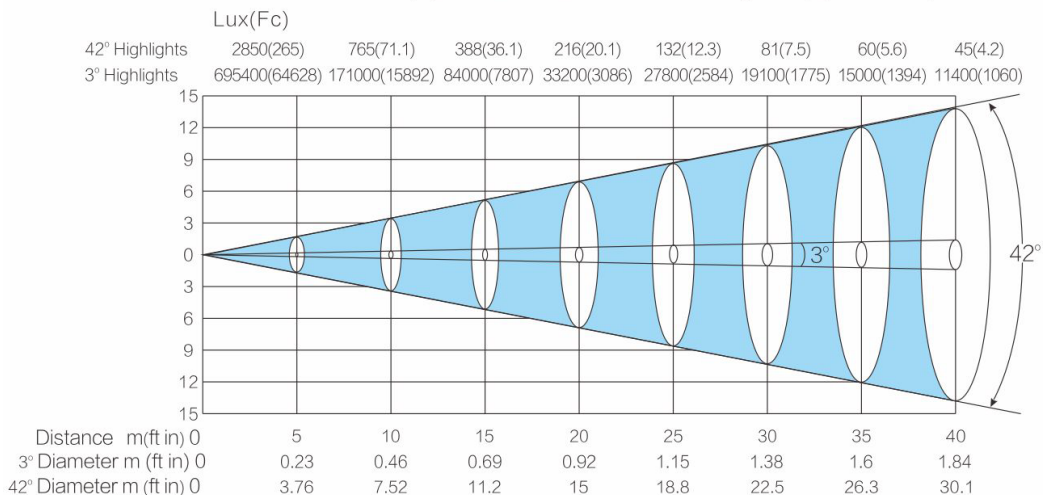

CIRCUIT CONNECTION DIAGRAM

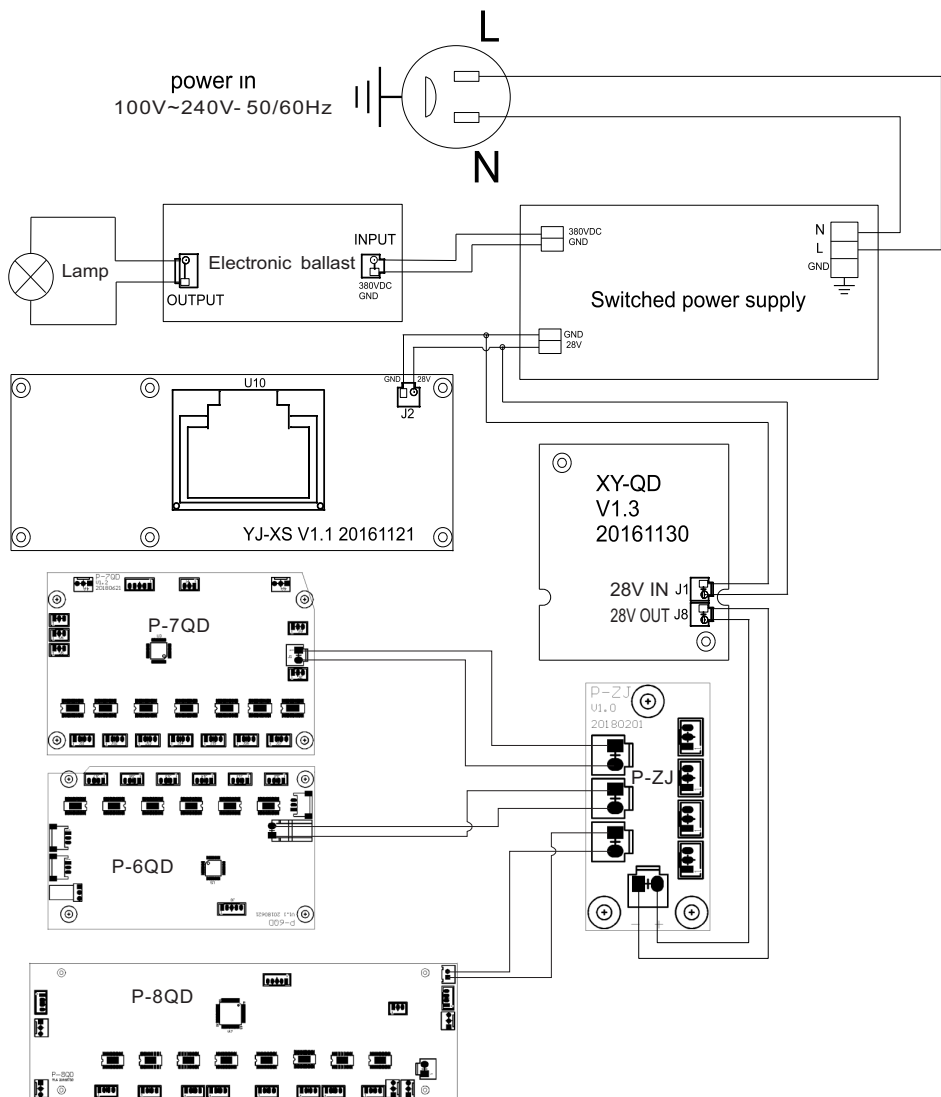

SPECIFICATIONS

Power

Input voltage & rate	AC100-240V~, 50/60HZ
Standby power	498W
Nominal total power consumption (at nominal voltage 230V)	630W
Typical current (at nominal voltage 230V)	2.7A
Cos ϕ	0.972
Power plug type	Seetronic Powercon TRUE

Source

Lamp	Osram Sirius HRI 471W SN
Expected Lifetime	1500 hours
CRI level	80 (Standard), 90+ (High)

Optical

Beam angle	Beam Projection 2-21° Spot Projection 3-42°
------------	--

Photometric

Output @1M	More info on page 23
Output @5M	More info on page 23

Effects

Color Mixing	CMY Fixed color wheel
Gobo	Rotating wheel 9 + open Fixed wheel 13 + open
Prism	Wheel 1: Linear, 4-facet, 8-facet Wheel 2: 8-facet
Zoom	2° - 42°
Frost	1° and 5° level frosts, combinable
Dimming	16 bit
Shutter	0.5 - 9 times/second, random
Pan	540°
Tilt	250°

Heat Management

Cooling type	Forced ventilation with axial fans
MAX ambient temp (Ta max)	Ta max=40°C

SPECIFICATIONS

MIN ambient temp (Ta min)	Ta min =-20°
MAX Housing temp (ta=25°C)	Tc=100°C
MAX Housing temp (ta=40°C)	Tc=100°C
Control	
Control protocol	DMX512
DMX Channels	33
RDM	Yes
ACN	No
DMX input connection	3-pin and 5-pin
Data input (artnet, SACN)	No
Hardware	
Interface	LCD Display
Software upload method	USB
Installation	
IP rating	IP20
Orientation	Any
Housing	
Safety attachment point	Bottom
Lock	Tilt lock
Physical	
Net product weight	29Kg
Dimensions	401x300x646mm (l x w x h)
Accessories	
Included items	Manual, Power cable, DMX cable, safety cable
Approvals	
Approved certifications	CE and RoHs
Information	
Article number	160025
EAN CODE	8719189163179

