



High End Systems SolaFrame Theatre Automated Luminaire User Manual

Version 1.2.10

Part Number: H730-MANL-1.2.10 Rev: A

Released: 2021-07

To view a list of ETC trademarks and patents, go to etconnect.com/ip. All other trademarks, both marked and not marked, are the property of their respective owners.

You can find complete High End Systems terms and conditions and warranty information at etconnect.com/Support/Warranty.aspx.

ETC intends this document, whether printed or electronic, to be provided in its entirety.

Table of Contents

- Introduction 1
 - Important Safety Information 1
 - Help from Technical Services 2
- Safety Considerations 3
 - General Operation and Use Guidelines 5
- Fixture Overview 6
- Install the Fixture 7
- Power 10
 - Electrical Specifications 10
 - Input and Power Factor 10
 - Connector Specification 10
 - Fixture Connection 10
- DMX Control 11
 - DMX Connector Pinout 11
 - Connect DMX Cables to Fixture 12
 - DMX Control and Ethernet Output 12
 - Terminate DMX 12
 - Set the DMX Start Address 13
 - DMX Channels 13

Ethernet Control	14
Connect Ethernet Cables to a Fixture	14
Ethernet Control and DMX Thru	15
Terminate DMX	15
Set the DMX Start Address	15
Set the Control Input and Universe	15
 Configure the Fixture	 16
Navigate the User Interface	16
Set Fixture Parameters	17
DMX Address	17
Info Menu	17
Set Menu	19
Test Menu	22
Preset Menu	23
 Error Codes	 24
 Maintenance	 26
Clean the Fixture	26
Replace the Fuse	26
 Compliance	 27
FCC Compliance	27
Declarations of Conformity	28

Introduction

Congratulations on your purchase of the SolaFrame Theatre automated framing fixture. This manual provides important information for the safe installation, configuration, and maintenance of your SolaFrame Theatre fixture.

Important Safety Information

Please read all instructions prior to assembling, mounting, and operating this equipment. Continued and safe operation of this fixture is the responsibility of the operator. This manual will give tips for that continued safe operation. At any time please contact Technical Services for any safety concerns.

The following international note, caution, and warning symbols appear in margins throughout this manual to highlight important messages.



Note: *Notes are helpful hints and information that is supplemental to the main text.*



CAUTION: *Hot Surfaces. This statement indicates that while operating, equipment surfaces may reach very high temperatures. Allow the fixture to cool before handling or servicing.*



CAUTION: *A Caution statement indicates situations where there may be undefined or unwanted consequences of an action, potential for data loss or an equipment problem.*



WARNING: **A Warning statement indicates situations where damage may occur, people may be harmed, or there are serious or dangerous consequences of an action**



WARNING: RISK OF ELECTRIC SHOCK! This warning statement indicates situations where there is a risk of electric shock.

All ETC High End Systems documents are available for free download from our website: etconnect.com/Products/High-End-Systems.

Please email comments about this manual to: TechComm@etconnect.com.

Help from Technical Services

If you are having difficulties and your problem is not addressed by this document, try the ETC support website at support.etconnect.com or the High End Systems product website at etconnect.com/Products/High-End-Systems. If none of these resources are sufficient, contact ETC Technical Services directly at one of the offices identified below. Emergency service is available from all offices outside of normal business hours.

When calling for help, take these steps first:

- Prepare a detailed description of the problem
- Go near the equipment for troubleshooting
- Find your notification number if you have called in previously

ETC, Inc.

Americas

Technical Services Department
3031 Pleasant View Road
Middleton, WI 53562
800-775-4382 (USA, toll-free)
+1-608 831-4116
service@etconnect.com

ETC Austin

High End Systems Products

Technical Services Department
2105 Gracy Farms Lane
Austin, TX 78758 USA
800-890-8989 (USA, toll-free)
+1-512 836-2242
hesservice@etconnect.com

ETC Ltd

Europe, Middle East, and Africa

Technical Services Department
26-28 Victoria Industrial Estate
Victoria Road,
London W3 6UU England
+44 (0)20 8896 1000
techservltd@etconnect.com

ETC GmbH

Germany, Austria, Switzerland, Eastern Europe, and Russia

Technical Services Department
Ohmstrasse 3
83607 Holzkirchen, Germany
+49 (80 24) 47 00-0
techserv-germany@etconnect.com

ETC France

France

Zone Urbaparc -
Bâtiment E
6 Boulevard de la Libération
Saint-Denis, 93200
+33 1 4243 3535
techservfrance@etconnect.com

ETC Asia

Asia





Technical Services Department
Room 1801, 18/F
Tower 1, Phase 1 Enterprise Square
9 Sheung Yuet Road
Kowloon Bay, Kowloon, Hong Kong
+852 2799 1220
techserv-asia@etconnect.com

Safety Considerations

To ensure safe operation, follow the safety instructions and warning notes in this user manual.

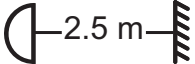
- The SolaFrame Theatre is intended for professional use only. Not for residential use. Read the entire manual before using this equipment.
- Contact your ETC authorized dealer or Technical Services before performing any service in order to maintain warranty coverage.

Symbols used on the product label are defined below:

	The luminaire must be installed at least 2.5 m (8 ft 3 in) away from all lighted objects.	Le luminaire doit être installé à au moins 2,5 m (8 pi. 3 po.) de tout objet éclairé.
	The luminaire operates at a temperature that allows it to be installed on normally flammable building materials, such as wood.	Le luminaire fonctionne à une température qui lui permet d'être installé sur des matériaux de construction normalement inflammables, comme le bois.
	Do not stare at the operating light source.	Ne pas regarder la source de lumière lorsqu'elle fonctionne.
	This product should not be discarded as unsorted waste but must be sent to separate collection facilities for recovery and recycling.	Ce produit ne doit pas être jeté avec les déchets ménagers mais doit être déposé dans une collecte de déchets électroniques ou dans un point de collecte.
	Operate indoors only, not where this product would be exposed to the weather.	Ne fonctionne qu'à l'intérieur, pas là où ce produit serait exposé aux intempéries.



WARNING: Note the following safety warnings before use:

- This equipment is designed for operation by qualified personnel only.
- Replace fuses with the specified type and rating only. See [page 26](#).
- Make sure that the available voltage is within the stated range. See [page 10](#).
- Do not use this fixture with a damaged power lead (cord set). If the lead is damaged, it must be replaced by a qualified technician with an equivalent type before use. Contact your local authorized dealer for spare power leads.
- Do not use this fixture if the lens, protection screen, or ultraviolet screen is damaged. Damaged lenses must be replaced before use. Contact your local authorized dealer for a replacement.
- Do not mount the fixture on or near flammable surfaces.
- Minimum distance from fixture head to combustible materials: 0.5 m (1 ft 8 in).
- Minimum distance to lighted objects: 2.5 m (8 ft 3 in).



AVERTISSEMENT : Pour votre sécurité, lisez les mises en garde et les avis suivants avant toute utilisation :

- Cet équipement est conçu pour être utilisé par un personnel qualifié uniquement.
- Remplacez les fusibles uniquement par le type et le calibre indiqués. Voir [page 26](#).
- Veillez à ce que la tension disponible soit dans la plage indiquée. Voir [page 10](#).
- N'utilisez pas ce projecteur avec un cordon d'alimentation endommagé (fils électriques). Si le cordon est endommagé, un technicien qualifié doit le remplacer par un cordon de type équivalent avant que l'appareil ne puisse être utilisé. Contactez votre distributeur agréé local pour obtenir des cordons d'alimentation de rechange.
- N'utilisez pas ce projecteur si la lentille, l'écran de protection ou l'écran ultraviolet sont endommagés. Les lentilles endommagées doivent être remplacées avant d'utiliser l'appareil. Contactez votre distributeur local agréé pour les remplacer.
- Ne pas installer le projecteur sur ou à côté d'une surface inflammable.
- Distance minimum entre la tête du luminaire et les matériaux combustibles : 0.5 m (1 ft 8 in).
- Distance minimale avec les objets éclairés : 2.5 m (8 ft 3 in).



WARNING: RISK OF ELECTRIC SHOCK!

- Do not operate this device with the cover open.
- Disconnect the fixture from power and DMX and allow it to cool before performing any cleaning and maintenance.



AVERTISSEMENT : RISQUE DE CHOC ÉLECTRIQUE!

- N'utilisez pas cet appareil avec le couvercle ouvert.
- Débrancher la lampe de son alimentation et du DMX et la laisser refroidir avant d'effectuer un nettoyage ou un entretien.



RISK GROUP 2: CAUTION. *Possibly hazardous optical radiation emitted from this product. Do not stare at operating lamp. May be harmful to the eyes.*

GROUPE DE RISQUE 2 (RISQUE MODÉRÉ) : ATTENTION. *Rayonnement optique potentiellement dangereux émis par ce produit. Ne regardez pas la lampe en fonctionnement. Peut être nocif pour les yeux.*



CAUTION: *Hot Surfaces. Allow the device to cool completely before handling and servicing.*



ATTENTION : *Surfaces chaudes. Laissez le luminaire refroidir complètement avant de le manipuler et de procéder à son entretien.*



Note: *The light source in this luminaire is not user-replaceable, and must be replaced only by a qualified technician. Contact ETC Customer Support for assistance.*

General Operation and Use Guidelines

- This fixture is only allowed to be operated with the maximum alternating current that is stated in the technical specifications label provided on the fixture.
- Lighting effects are not designed for permanent operation. Consistent operation breaks may extend the life of the fixture.
- When choosing the installation location, make sure the fixture will not be exposed to extreme heat, moisture, or dust.
- Do not point the lens toward the sun or other bright light source. Doing so could damage the fixture.
- If using the supplied Omega brackets with quick-locking thumb screws for fixture hanging, ensure that the thumb screws have engaged a complete 90-degree positive latch.
- Operate the fixture only after having familiarized yourself with its functions. Do not permit persons who are not qualified and familiar with its functions to operate the fixture.
- Do not modify the fixture. Any modifications will void the warranty.
- This manual describes the proper installation and operation of this fixture. Using this fixture in any way other than the intended use may cause damage and void the warranty.
- When the fixture has been stored or transported in cold temperatures, allow it to warm to room temperature for a minimum of one hour before applying power. Applying power to a cold fixture may cause damage to the fixture and void the manufacturer warranty.
- When you power on the fixture, you may notice smoke or odor. This is normal and should decrease gradually. If smoke or odor persists, disconnect the fixture from power and contact your ETC dealer or Technical Services.
- Please use the original packaging if the fixture is to be transported. ETC will not be responsible for the fixture if packaging other than manufacturer provided packaging is used.

Fixture Overview

For current and complete technical specifications for the SolaFrame Theatre fixture, see the technical datasheet:

etconnect.com/Products/High-End-Systems/Lighting-Fixtures/SolaFrame/Theatre/Documentation.aspx

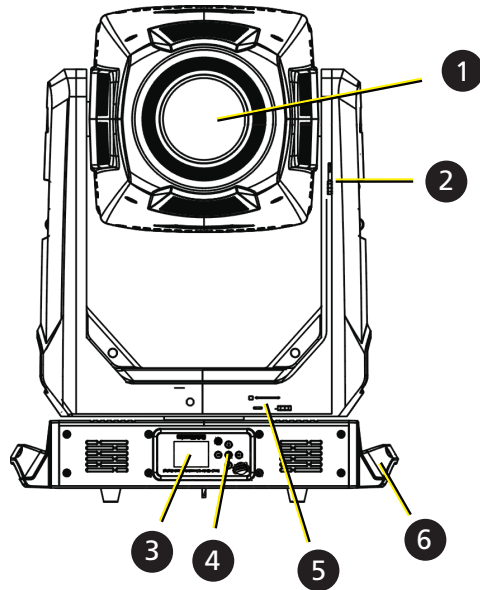

- 1: Lens
- 2: Tilt Lock
- 3: Display
- 4: Navigation Controls
- 5: Pan Lock
- 6: Handle
- 7: Fuse
- 8: Power In and Power Out
- 9: DMX In
- 10: DMX Out
- 11: Ethernet Ports (x2)

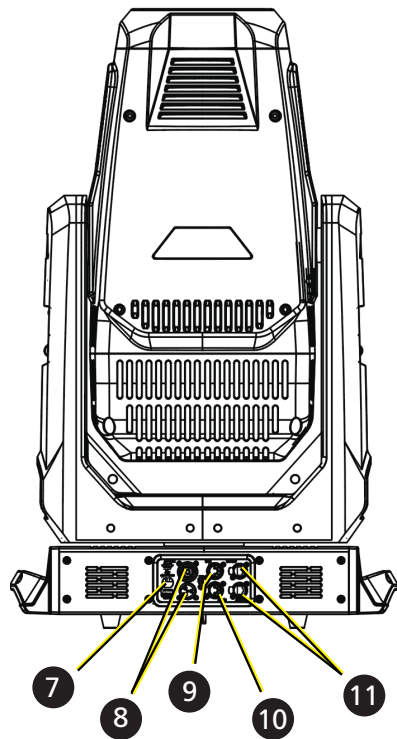

Install the Fixture



WARNING:

- NEMA Type 1 enclosure, indoor use, dry locations only. Do not use outdoors. This fixture is intended for use where humidity does not exceed 90% (non-condensing).
 - The operating temperature range for this fixture is 0°C–35°C (32°F–95°F). Do not operate the fixture outside of this range.
 - The installation location must support a minimum point load of 10 times the weight of the fixture.
 - The installation must always be secured with a secondary safety attachment. An appropriate safety cable is supplied.
 - Safety cable attachment must be rated by a safety factor of 10.
 - Use of third party clamps are permitted, but they should comply with, and be approved by, the Authority Having Jurisdiction (AHJ).
 - A supportive and stable surface must be used when the fixtures are placed on the feet.
 - Never stand directly below the installed fixture when mounting, removing, or servicing the fixture.
 - All safety and technical aspects of fixture installation must be approved by a qualified personnel before operation.
 - The installation must be regularly inspected by qualified personnel.
 - Overhead rigging must be performed by qualified personnel.
-



AVERTISSEMENT :

- Boîtier NEMA de type 1, utilisation en intérieur, emplacements secs uniquement. Ne l'utilisez pas en extérieur. Ce projecteur est conçu pour être utilisé dans des environnements où l'humidité ne dépasse pas 90 % (sans condensation).
 - La plage de température de fonctionnement de ce projecteur est de 0°C–35°C (32°F–95°F). Ne faites pas fonctionner le projecteur au-delà de cette plage.
 - L'emplacement d'installation doit supporter une charge concentrée minimale de 10 fois le poids de l'appareil.
 - L'installation doit toujours être sécurisée par une fixation de sécurité auxiliaire. Un câble de sécurité approprié est fourni.
 - La fixation du câble de sécurité doit être classée avec un facteur de sécurité de 10.
 - Il est permis d'utiliser des pinces provenant de tiers, mais elles doivent être conformes et approuvées par l'Autorité compétente (AC).
 - Une surface d'appui stable doit être utilisée quand les projecteurs sont placés sur pieds.
 - Ne vous placez jamais directement sous le projecteur lors du montage, du démontage ou de son entretien.
 - Tous les aspects techniques et de sécurité de l'installation du projecteur doivent être approuvés par un personnel qualifié avant qu'il ne soit utilisé.
 - L'installation doit être régulièrement inspectée par du personnel qualifié.
 - La fixation en hauteur doit être effectuée par du personnel qualifié.
-



CAUTION: *Follow all local codes and recommended practices by the Authority Having Jurisdiction. The installation must only be carried out by qualified personnel.*

ATTENTION : *Respectez tous les règlements locaux et toutes les pratiques recommandées par l'autorité compétente. L'installation doit être effectuée uniquement par du personnel qualifié.*

You can install the fixture in any of the orientations shown below.

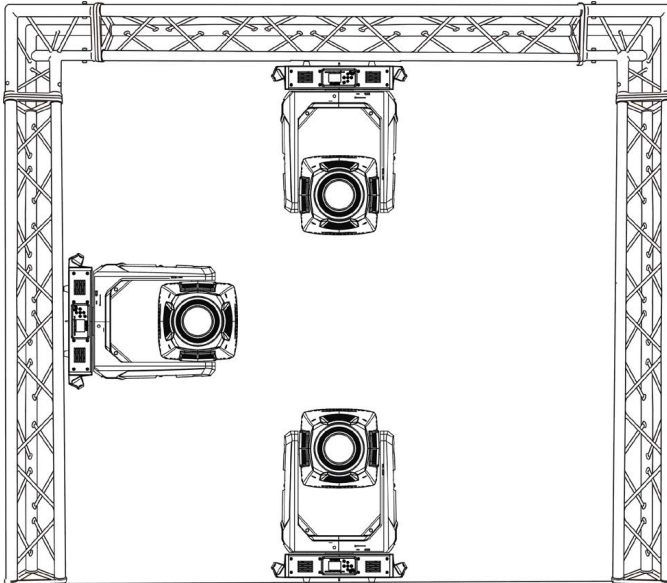

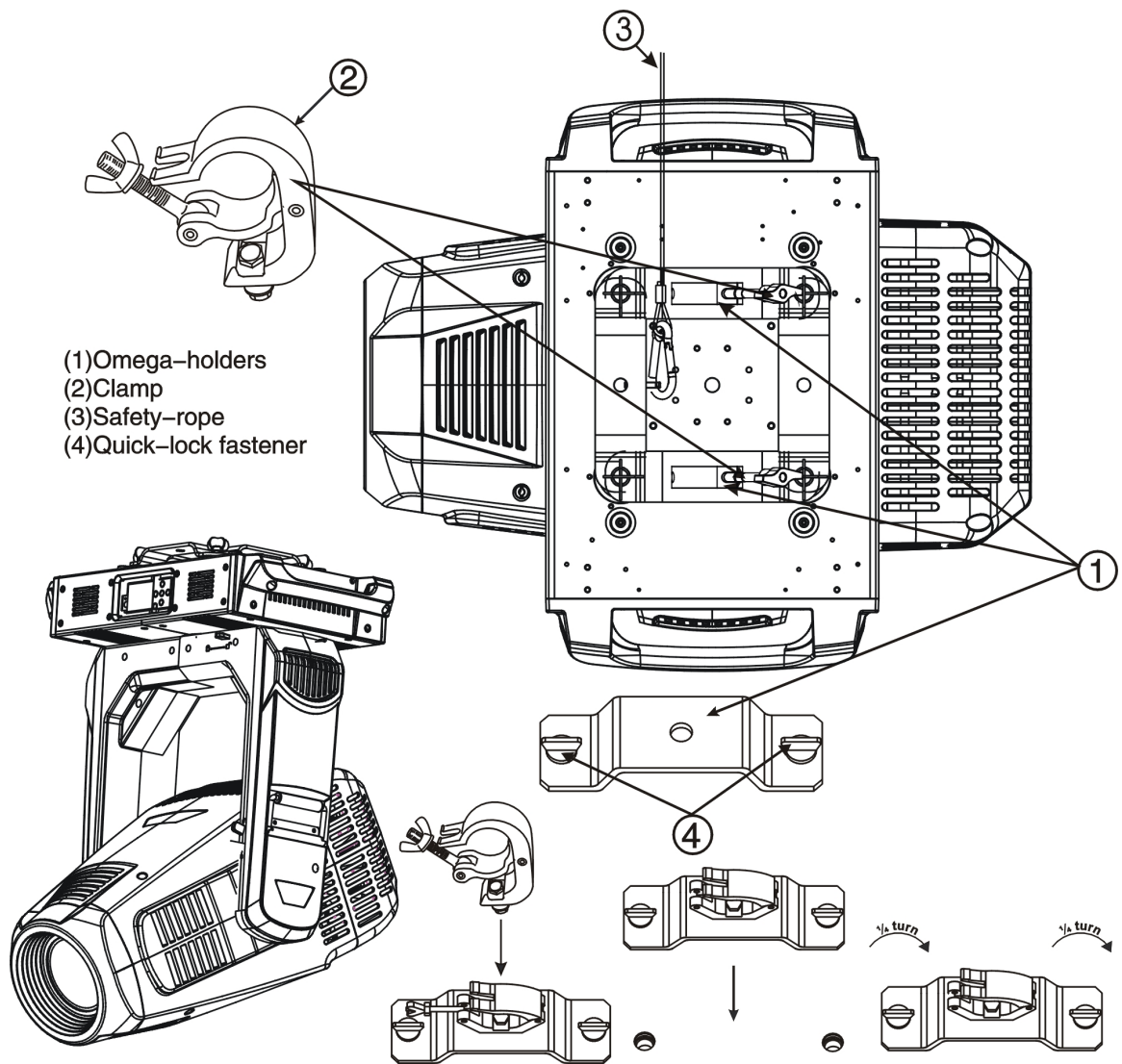

- (1)Omega-holders
- (2)Clamp
- (3)Safety-rope
- (4)Quick-lock fastener

1. Assemble the clamp (provided by others) to the Omega bracket that was provided with the fixture and secure together using appropriately sized hardware (not provided).
2. Align the assembled Omega bracket and quick-lock fasteners into the respective holes on the bottom of the fixture upper enclosure.
3. Tighten each of the quick-lock fasteners fully, turning clockwise. You will hear and feel a click when the fastener is fully secured.
4. Repeat steps 1 through 3 for the second clamp and bracket.
5. Attach the provided safety cable through the attachment point on the bottom of the fixture upper enclosure and secure to the trussing system or other safe installation point. Follow local codes and recommended safety standards for securing the fixture to the installation location.
6. Attach the fixture to the installation location using the installed clamps, using the clamp manufacturer's instructions for a secure fit. When using an Omega clamp, close the safety and fully tighten the clamp wing nut until secure.
7. Inspect the installation prior to lifting the fixture overhead.

Power

Electrical Specifications

- 100–240 VAC at 50/60 Hz
- Maximum power consumption: Standard mode 703 W; with Defogger 738 W

Input and Power Factor

VAC	Amps	Hz	Watts	VA	PF
100	7.4	50	738	752	0.98
120	6.1	60	725	722	0.98
200	3.6	50	721	720	0.96
208	3.5	60	728	709	0.96
220	3.3	50	711	720	0.95
230	3.2	50	720	725	0.95
240	3.1	60	730	730	0.95

Connector Specification



WARNING: Risk of Shock and Fire. Assemble a grounding-type attachment plug with integral cord grip that is within the voltage and amperage rating of this luminaire.

AVERTISSEMENT : Risque de choc et d'incendie. Assurez-vous d'utiliser une prise de mise à la terre avec décharge de traction intégrée qui respecte la tension et l'ampérage de ce luminaire.

A power input cable with powerCON® TRUE1® TOP input to bare ends is provided. The power input cable is rated for maximum 20 A/120 VAC and 16 A/240 VAC. Install a suitable connector to meet the installation requirements. See the following wire color code chart:

Wire Color Code (EU)	Wire Color Code (US Standard)	Connection type	Terminal
Green/Yellow	Green	Earth/Ground	
Blue	White	Neutral	N
Brown	Black	Line (Live)	L

Fixture Connection

Voltage	Maximum Number of Fixtures Connected via Power In/Out	Notes
100 V–120 V	2	For more than two devices, connect the third device directly to mains power.
200 V–240 V	3	For more than three devices, connect the fourth device directly to mains power.

DMX Control

The SolaFrame Theatre fixture operates on standard DMX-512 control bus, controlled by a DMX console. The fixture requires 47 channels of DMX-512.

Attach the fixture to the control bus using a two-core, shielded cable with a 5-pin XLR connector (Belden 9729 is preferred).

Two XLR termination receptacles are available: one for connection of DMX Input, and one for DMX Out (used when daisy-chaining to additional fixtures on the DMX control bus).

DMX Connector Pinout

For DMX Input, the DMX cable must have a XLR plug connector on one end of the cable that connects to the fixture. When daisy-chaining DMX to the next device, prepare a DMX cable with a XLR socket connector on one end and a XLR plug connector on the other end. Terminate the cable ends as indicated in the pinout image below.

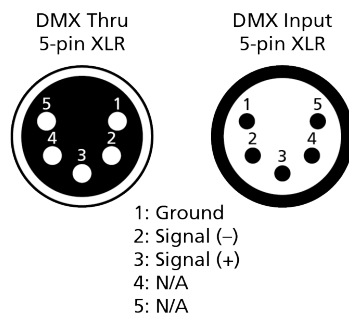

Connect DMX Cables to Fixture

The following instructions are guidelines for connecting DMX to your fixture. Your installation may vary.

1. Connect the XLR plug connector of a DMX data cable to the DMX Out connector on the DMX control source.
2. Connect the XLR socket connector of the DMX data cable to the DMX In connector of the first fixture on the DMX control run.
3. Continue linking the remaining fixtures by connecting a cable from the DMX Out connector of a fixture to the DMX In connector of the next fixture on the control run.



Note: A maximum of 32 DMX devices may be connected in any one DMX data run when installed in a daisy-chain fashion.

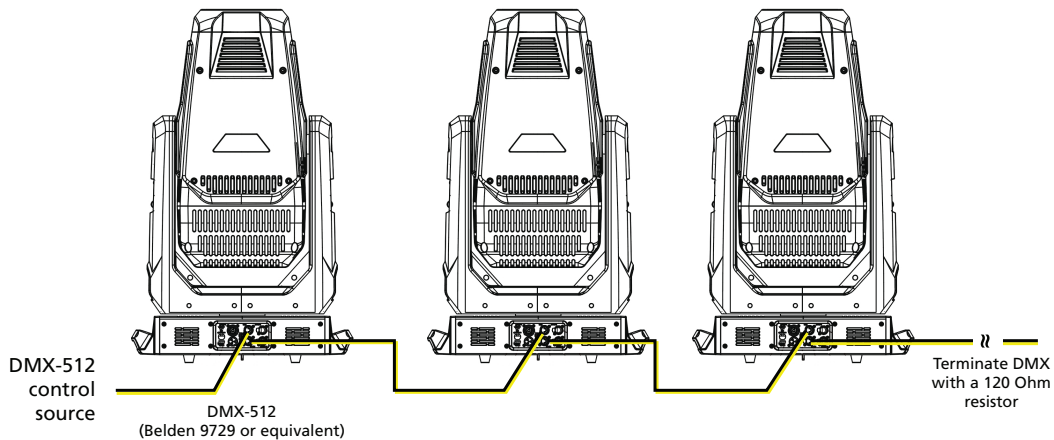

DMX Control and Ethernet Output

You can use DMX-512 control and Ethernet output. When a fixture is set up to receive DMX-512 control input, it converts the signal to Art-Net on IP10 and sends the signal to the Ethernet port, continuing the Art-Net on IP10 signal to the next fixture in the control run.

Terminate DMX

Use a DMX terminator or install a resistor on the last fixture of the DMX control run to prevent corruption (data reflection) of the digital control signal by electrical noise.

A DMX terminator is an XLR plug with a 120 Ω resistor connected between pins 2 and 3 that can be installed into the DMX output receptacle of the last fixture in the DMX control run. This plug is available and sold separately. Contact your authorized dealer or ETC for ordering information (etcconnect.com/contactETC/).

Set the DMX Start Address

Give each fixture a unique DMX starting address so that the correct fixture responds to the control signals. This DMX start address is the channel number from which the fixture starts to “listen” to the digital control information sent out from the control source.

Modify the fixture DMX start address on the user interface, located on the upper enclosure. See [DMX Address on page 17](#).



Example: The SolaFrame Theatre has 47 channels. If you set the DMX starting address of the first fixture to 1, you could set the second fixture to 48 ($47+1$), the third to 95 ($48+47$), and so on.

DMX Channels

The current DMX channel map for the SolaFrame Theatre can be found on the ETC website:

etcconnect.com/Products/High-End-Systems/Lighting-Fixtures/SolaFrame/Theatre/Documentation.aspx

Ethernet Control

The SolaFrame Theatre fixture includes two Ethernet ports that allow sending and receiving of control signals using the Art-Net protocol or sACN.

Use a Cat5e (or better) cable and terminate to RJ45 connectors following the TIA/EIA 568B wiring standard.

Connect Ethernet Cables to a Fixture

The following instructions are guidelines for connecting Ethernet to your fixture. Your installation may vary.

1. Connect a cable from the Ethernet control source to one of the Ethernet ports on the first fixture in the Ethernet control run.
2. Connect the first fixture to a second fixture by connecting a cable from the second Ethernet port on the first fixture to one of the Ethernet ports on the second fixture.
3. Continue linking the remaining fixtures by connecting a cable from Ethernet port to Ethernet port on the fixtures on the control run.



Note: *The Cat5e cable distance should not exceed 100 m (328 ft), and you should not connect more than 20 fixtures in one Ethernet control run when the fixtures are linked together.*

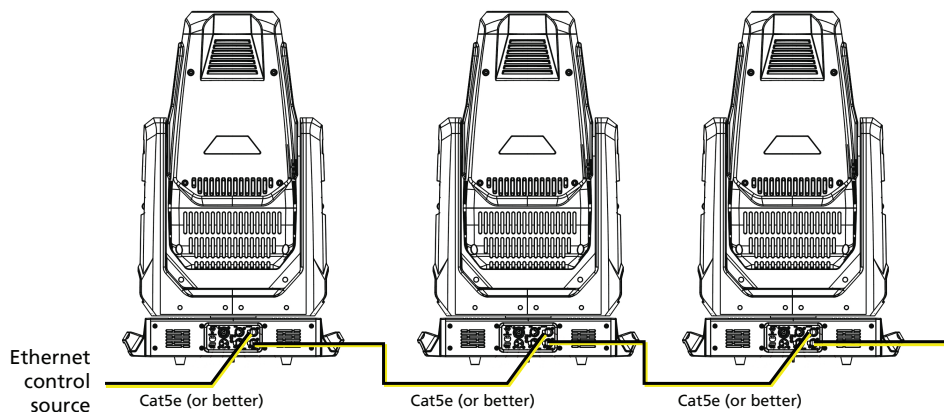

Ethernet Control and DMX Thru

You can use Ethernet control and DMX Thru. When a fixture is set up to receive Ethernet control input, it automatically distributes DMX via the DMX Thru port. The DMX-512 signal is sent as a single universe that corresponds to the universe of the fixture that is receiving Ethernet control.

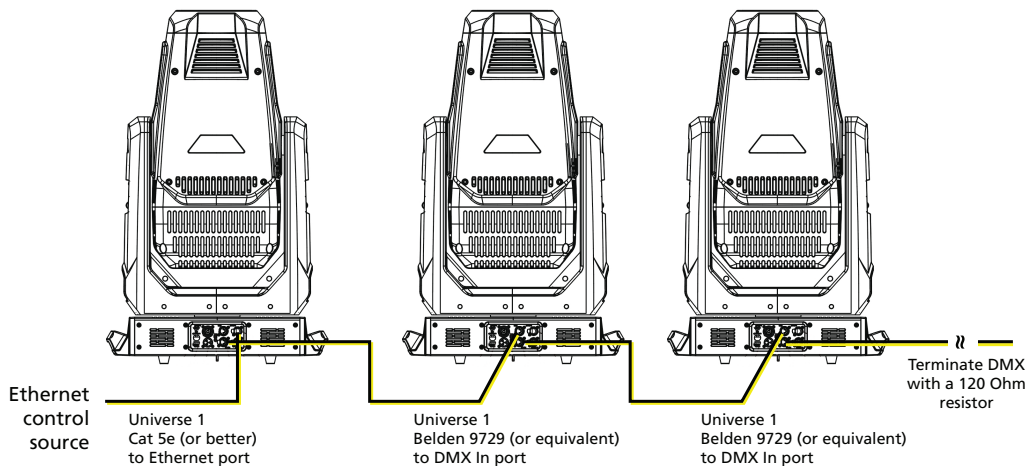

Terminate DMX

Use a DMX terminator or install a resistor on the last fixture of the DMX control run to prevent corruption (data reflection) of the digital control signal by electrical noise.

A DMX terminator is an XLR plug with a 120 Ω resistor connected between pins 2 and 3 that can be installed into the DMX output receptacle of the last fixture in the DMX control run. This plug is available and sold separately. Contact your authorized dealer or ETC for ordering information (etcconnect.com/contactETC/).

Set the DMX Start Address

Give each fixture a unique DMX starting address so that the correct fixture responds to the control signals. This DMX start address is the channel number from which the fixture starts to “listen” to the digital control information sent out from the control source.

Modify the fixture DMX start address on the user interface, located on the upper enclosure. See [DMX Address on page 17](#).



Example: The SolaFrame Theatre has 47 channels. If you set the DMX starting address of the first fixture to 1, you could set the second fixture to 48 (47+1), the third to 95 (48+47), and so on.

Set the Control Input and Universe



For Ethernet control, you must configure the control input (Art-Net on IP2, Art-Net on IP10, or sACN) and set a universe for each fixture. See [Select Input on page 20](#) and [Set Universe for Art-Net and sACN on page 20](#) for details.

Configure the Fixture

You can configure SolaFrame Theatre fixtures through the onboard user interface.

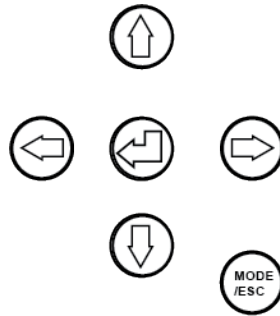
Navigate the User Interface



1. Press and hold the [MODE/ESC] button until the display flashes. (The display is powered by battery when the fixture has no power.)
2. Browse the menu by pressing the up, down, left, or right navigation buttons.
3. Press the Enter button  to select a menu item.
4. Modify the selection by pressing the up, down, left, or right navigation buttons according to the selection.
5. Press the Enter button  to confirm a modified selection.
6. To exit the menu, press the [MODE/ESC] button.



Note: *If you press the Enter button to confirm a selection and push no other buttons, the user interface returns to the default display after 10 seconds.*

Set Fixture Parameters

This section provides instructions to configure and set up the SolaFrame Theatre. See [Navigate the User Interface on page 16](#) for information about the navigation buttons.

Provide power to the fixture before configuring it. If you do not provide power, the fixture will use battery power to power the user interface.

DMX Address

Navigate: Main Menu → Address

Set the DMX address for the fixture. The default value is 001.

Info Menu

Set the Time Information

Navigate: Main Menu → Info → Time Info

Parameter	Value	Description
Current Time	XXXX (Hours)	Running time of the fixture from the last time that the fixture was powered on, shown in hours (h). The counter resets after the fixture is turned off.
Ttl Life Hrs	XXXX (Hours)	Total running time of the device, shown in hours (h).
Last Run Hrs	XXXX (Hours)	Running time of the fixture from the last time that the run time value was reset, shown in hours (h).
LED Hours	XXXX (Hours)	Total running time of the fixture LEDs, shown in hours (h).
Timer PIN	Timer PIN XXX	You must enter the Timer PIN in order to access the Clr Last Run menu item. The default Timer PIN is 038.
Clr Last Run	<ul style="list-style-type: none">• ON• OFF	This password-protected menu item resets the Last Run Hrs value. You must enter the Timer PIN to access this menu item. Select ON to clear the value for the Last Run Hrs parameter for the fixture.
LED Time PIN	LED Time PIN XXX	You must enter the LED Time PIN in order to access the Clear LED Time menu item. The default LED Time PIN is 038.
Clear LED Time	<ul style="list-style-type: none">• ON• OFF	This password-protected menu item resets the LED Hours value. You must enter the LED Time PIN to access this menu item. Select ON to clear the value for the LED Hours parameter.

View Fixture Errors

Navigate: Main Menu → Info → Error Info

Displays any current fixture errors. See [Error Codes on page 24](#) for information about the errors.

View DMX Values for Channels

Navigate: Main Menu → Info → Value Disp.

View the DMX value of each of the fixture's channels (parameters of the fixture). Scroll to the parameter that you want to view (Pan, Tilt, etc.) and view the value. The DMX value that you view is the DMX value that displays on the main window of the UI until you select a different DMX value to view.

View Fixture Head Temperature

Navigate: Main Menu → Info → Head Temp

Displays the current fixture temperature as read from the fixture head (near the CMY filter).

View Ethernet IP Address

Navigate: Main Menu → Info → Ethernet IP

Displays the Ethernet IP address for the fixture. You can modify this value in the Set menu. See [Access Service Settings on page 21](#).

View Software Version

Navigate: Main Menu → Info → Software Ver

Displays the software version for the fixture.

Set Menu

Set the Status Options

Navigate: Main Menu → Set → Status

Parameter	Value	Description
No DMX Mode	<ul style="list-style-type: none">• Close• Hold• Auto• Music	Control mode when DMX is absent. The default value is Hold.
Pan Reverse	<ul style="list-style-type: none">• ON• OFF	Reverse the pan movement of the fixture. The default value is OFF.
Tilt Reverse	<ul style="list-style-type: none">• ON• OFF	Reverse the tilt movement of the fixture. The default value is OFF.
Pan Degree	<ul style="list-style-type: none">• 630• 540	Change the pan rotation of the fixture from the default setting of 540 degrees to 630 degrees.
Encoders	<ul style="list-style-type: none">• ON• OFF	Turn on or off the encoder feedback for pan and tilt movement. You may want to turn off encoders when working on a fixture so that you can move pan and tilt without the fixture automatically moving back to position.
Pan/Tilt Spd	1–4	Set the speed (scan mode) of pan and tilt movement. The default value is 1. Use this parameter to make fine adjustments to pan and tilt movement in order to correct for mis-stepping when the fixture is installed on its side (side-hung, or "Outrig").
Hibernation	<ul style="list-style-type: none">• OFF• 1–99 minutes	Hibernation mode forces the LEDs and stepper motors to power off when the fixture loses DMX control signal for a set period of time. The default time setting is 15 minutes.
Defogger	<ul style="list-style-type: none">• Defog OnOP• Defog OnPwr• Defog Off	Set when the Defogger (heater for the front lens) is turned on: <ul style="list-style-type: none">• Defog OnOP: Turn on Defogger when LEDs are above 0% intensity• Defog OnPwr: Turn on Defogger when the fixture is powered (default value)• Defog Off: Turn off Defogger
Dimming Mode	<ul style="list-style-type: none">• 16 kHz• 2.4 kHz• 100 Hz	Set the dimming curve and pulse width modulation (PWM) frequency. The default value is 16 kHz. <ul style="list-style-type: none">• 16 kHz is quieter than 2.4 kHz and creates a beam that does not flicker when shown on camera.• 2.4 kHz prioritizes flawless, stepless dimming.• 100 Hz reduces the noise level further than 16 kHz while still achieving step-less dimming, but it has a noticeable flicker on most video cameras.
CMY Curve	<ul style="list-style-type: none">• Linear• Non-Linear	Set the CMY curve. The default value is Linear.

Select Input

Navigate: Main Menu → Set → Select Input

Select the control input for the fixture:

- DMX Only
- Art-Net on IP2
- Art-Net on IP10
- sACN

Set Universe for Art-Net and sACN

Navigate: Main Menu → Set → Set Universe

When using Art-Net control input, set a universe value of 000–255.

When using sACN control input, set a universe value of 001–255.

Access Service Settings

Navigate: Main Menu → Set → Service PIN

Parameter	Value	Description
Service PIN	Service PIN XXX	You must enter the Service PIN in order to access the other Service Setting parameters. The default Service PIN is 050.
RDM UID	Manufacturer ID and fixture serial number	<p>This password-protected menu item lets you modify the RDM UID. You must enter the Service PIN to access this menu item.</p> <p>Note: Remote Device Management (RDM) requires that all RDM devices have a unique identifier (UID) that consists of the manufacturer ID and serial number. Modifying this setting can break the RDM capability of this fixture.</p> <p>Duplicate RDM UIDs on the same DMX control run will result in a data collision, causing a communication failure. Ensure that all fixtures have a unique RDM UID if RDM functionality is to be used.</p> <p>If DMX splitters are used and RDM control is to be used, these splitters must support RDM.</p>
Ethernet IP	XXX.XXX.XXX.XXX	This password-protected menu item lets you modify the IP address. You must enter the Service PIN to access this menu item. The default IP address is 002.142.058.034.
Ethernet Mask IP	XXX.XXX.XXX.XXX	This password-protected menu item lets you modify the IP subnet mask. You must enter the Service PIN to access this menu item. The default IP subnet mask is 255.000.000.000.
Clr Err Info	<ul style="list-style-type: none"> • ON • OFF 	<p>This password-protected menu item lets you clear error messages after you have fixed the errors. You must enter the Service PIN to access this menu item.</p> <p>Set this parameter to ON in order to clear the error messages. The default setting is OFF.</p>

Set Display Settings

Navigate: Main Menu → Set → Disp. Setting

Parameter	Value	Description
Shutoff Time	02–60 minutes	Enter the amount of time the fixture waits after the last user interface button press until the display goes to sleep. The default value is 5 minutes.
Flip Display	<ul style="list-style-type: none">• ON• OFF	Flip the display 180° when the fixture is mounted vertically. The default value is OFF. Shortcut: With the main UI window displayed, press [>] to flip the display 180°. Press [<] to flip it back to its original orientation.
Key Lock	<ul style="list-style-type: none">• ON• OFF	Lock the user interface. The default value is OFF. To unlock the user interface buttons, press and hold the [MODE/ESC] button for three seconds.

Set the Temperature Scale

Navigate: Main Menu → Set → Temp. C/F

Select the temperature scale for the fixture:

- Celsius (default value)
- Fahrenheit

Reset Fixture to Factory Default Settings

Navigate: Main Menu → Set → Reset Default

Select ON to reset the fixture to the factory default settings.

Test Menu

Reset (Home) the Mechanical Positions on the Fixture

Navigate: Main Menu → Test → Home

Reset ("home") all features on the fixture, including, pan, tilt, colors, gobos, etc.

Test an Individual Channel

Navigate: Main Menu → Test → Test Channel

Run a self-test program on individual channels. The default value is Control. Select a different channel to run a self-test on that channel.

Manually Set an Individual Channel

Navigate: Main Menu → Test → Manual Ctrl.

Select an individual channel on the fixture and manually set the channel value. While in Manual Control mode, all effects are canceled, the shutter opens, and the dimmer intensity is set to 100%.

Re-Calibrate an Individual Feature

Navigate: Main Menu → Test → Calibration

Please contact Technical Services before using this parameter. See [Help from Technical Services on page 2](#).

You must enter the Calibration PIN in order to access the Calibration menu items. The default Calibration PIN is 050.

Once you have accessed the Calibration menu, select an individual feature on the fixture and manually calibrate it to a new "home" setting.



Note: *Changes you make to the fixture settings in the Calibration menu are not changed if you reset the fixture to the factory default settings. The Calibration settings are saved until they are changed in the Calibration menu.*

Preset Menu

Navigate: Main Menu → Preset

Presets are built by combining scenes into programs and then assigning the programs to Program Partitions for playback. For information about the **Preset** menu, access the *High End Systems Preset Menu Guide* from the ETC website: support.etcconnect.com/Source_Articles/HES/Sola_Series_Fixtures/High_End_Systems_Preset_Menu_Guide.

Error Codes

When you apply power to the fixture, it runs a calibration (homing) sequence and displays any errors that it detects.



Example: When the display shows “Err Info: Pan Movement”, it means there is an error in channel 1. When multiple errors are present they will cycle on the display twice, and then the fixture will reset (restart). Any errors that remain after two reset cycles are not correctable by reset alone and will require service. These errors are stored in the fixture error history until the errors are cleared. Please contact Technical Services for assistance.

Animation

This message displays after the reset of the fixture if any of the following conditions exist:

- the magnetic-indexing circuit malfunctions (optical or magnetic sensor failure)
- the stepper motor is defective or the related IC driver on the main PCB has failed
- the Animation wheel is not located in the default position after the reset

Blade Rot

This message displays after the reset of the fixture if any of the following conditions exist:

- the magnetic-indexing circuit malfunctions (optical or magnetic sensor failure)
- the stepper motor is defective or the related IC driver on the main PCB has failed
- the Blade rotation is not located in the default position after the reset

Color

This message displays after the reset of the fixture if any of the following conditions exist:

- the fixture head's magnetic-indexing circuit malfunctions (optical or magnetic sensor failure)
- the stepper motor is defective or the related IC driver on the main PCB has failed
- the Color wheel is not located in the default position after the reset

Focus

This message displays after the reset of the fixture if any of the following conditions exist:

- the magnetic-indexing circuit malfunctions (optical or magnetic sensor failure)
- the stepper motor is defective or the related IC driver on the main PCB has failed
- the Focus wheel is not located in the default position after the reset

Gobo 1

This message displays after the reset of the fixture if any of the following conditions exist:

- the magnetic-indexing circuit malfunctions (optical or magnetic sensor failure)
- the stepper motor is defective or the related IC driver on the main PCB has failed
- Gobo Wheel 1 is not located in the default position after the reset

Gobo 2

This message displays after the reset of the fixture if any of the following conditions exist:

- the magnetic-indexing circuit malfunctions (optical or magnetic sensor failure)
- the stepper motor is defective or the related IC driver on the main PCB has failed
- Gobo Wheel 2 is not located in the default position after the reset

Gobo Rot 1

This message displays after the reset of the fixture if any of the following conditions exist:

- the magnetic-indexing circuit malfunctions (optical or magnetic sensor failure)
- the stepper motor is defective or the related IC driver on the main PCB has failed
- Gobo Rotating Wheel 1 is not located in the default position after the reset

Pan movement

This message displays after the reset of the fixture if any of the following conditions exist:

- the yoke's magnetic-indexing circuit malfunctions (optical or magnetic sensor failure)
- the stepper motor is defective or the related IC driver on the main PCB has failed
- the Pan movement is not located in the default position after the reset

Tilt movement

This message displays after the reset of the fixture if any of the following conditions exist:

- the fixture head magnetic-indexing circuit malfunctions (optical or magnetic sensor failure)
- the stepper motor is defective or the related IC driver on the main PCB has failed
- the Tilt movement is not located in the default position after the reset

Zoom

This message displays after the reset of the fixture if any of the following conditions exist:

- the magnetic-indexing circuit malfunctions (optical or magnetic sensor failure)
- the stepper motor is defective or the related IC driver on the main PCB has failed
- the Zoom wheel is not located in the default position after the reset

Maintenance



CAUTION: *RISK OF ELECTRIC SHOCK! Disconnect power before servicing.*

ATTENTION : *RISQUE DE CHOC ÉLECTRIQUE! Couper l'alimentation avant l'entretien.*

Keep the following in mind during regular service and inspection:

- All screws for installing the fixture or parts of the fixture must be tightly connected and must not be corroded.
- There must not be any deformations to the housing, lenses, rigging, and installation points (ceiling, suspension, trussing).
- Moving parts must not show any signs of wear and must move smoothly without issue.
- The power supply cables must not show any damage, material fatigue, or sediment.
- If spare parts are required, order only genuine parts from your local authorized dealer.

To ensure that the fixture remains in good working condition and does not fail prematurely, regular maintenance is recommended.

Clean the Fixture

1. Clean the inside and outside of the lens regularly using a damp, lint-free cloth to avoid loss of output due to accumulation of dust/dirt on the lens. Never use alcohol or solvents.
2. Clean the fixture and vents regularly to ensure maximum airflow and efficient cooling. This will ensure the light source operates in the best possible condition.

Replace the Fuse



WARNING: Replace fuses with the specified type and rating only.

AVERTISSEMENT : Remplacez les fusibles uniquement par le type et le calibre indiqués.



CAUTION: *RISK OF ELECTRIC SHOCK! Disconnect power before servicing.*

ATTENTION : *RISQUE DE CHOC ÉLECTRIQUE! Couper l'alimentation avant l'entretien.*

A replaceable AC line fuse is provided in the fixture to prevent overload.

Supplies needed:

- Flatblade screwdriver
 - One replacement fuse: 12 A 250 V 6x32 mm VDE slow-blow ceramic
1. Disconnect power to the fixture.
 2. Using a flatblade screwdriver, push the fuse holder in and twist it to remove it from the fixture. (See [Fixture Overview on page 6](#) for the location of the fuse holder.)
 3. Remove the blown fuse from the holder and replace it with another 12 A 250 V 6x32 mm VDE slow-blow ceramic fuse.
 4. Reinstall the fuse holder. Using a flatblade screwdriver, push the holder in and twist it until it is secure in the fixture.

Compliance

For current and complete compliance information, view the SolaFrame Theatre datasheet:

etconnect.com/Products/High-End-Systems/Lighting-Fixtures/SolaFrame/Theatre/Documentation.aspx

FCC Compliance

SolaFrame Theatre

(For any FCC matters):

Electronic Theatre Controls, Inc.
3031 Pleasant View Road
Middleton, WI 53562
+1 (608) 831-4116
etconnect.com

This device complies with Part 15 of the FCC Rules. Operation is subject to the following two conditions: (1) this device may not cause harmful interference, and (2) this device must accept any interference received; including interference that may cause undesired operation. Visit etconnect.com/products for current and complete compliance information including FCC compliance.



Note: *This equipment has been tested and found to comply with the limits for a Class A digital device, pursuant to Part 15 of the FCC rules. These limits are designed to provide reasonable protection against harmful interference when the equipment is operated in a commercial environment. This equipment generates, uses, and can radiate radio frequency energy and, if not installed and used in accordance with the instructions, may cause harmful interference to radio communications. Any modifications or changes to this product not expressly approved by Electronic Theatre Controls, Inc. could void the user's authority to operate the product. Operation of this equipment in a residential area is likely to cause harmful interference, in which case the user will be required to correct the interference at their own expense.*

Declarations of Conformity



EC DECLARATION OF CONFORMITY



We, Electronic Theatre Controls France SAS
declare under sole responsibility that the product(s):

Product series: High End Systems Sola LED luminaire

Product type/model: SolaFrame Theatre

to which this declaration relates is/are in conformity with the following Directives by the application of the quoted Standards.

Low Voltage Directive (LVD) 2014/35/EU:

EN 60598-1:2015	Luminaires. General requirements and tests
EN 60598-2-17:1989	Luminaires. Particular requirements. Specification for luminaires for stage lighting, television, film and photographic studios (outside and indoor)
EN 62471:2008	Photobiological safety of lamps and lamp systems
EN 61347-1:2015	Lamp controlgear. General and safety requirements
EN 61347-2-13:2014	Lamp controlgear. Particular requirements for d.c. or a.c. supplied electronic controlgear for LED modules

Electromagnetic Compatibility Directive (EMCD) 2014/30/EU:

EN 55015:2013+A1:2015	Limits and methods of measurement of radio disturbance characteristics of electrical lighting and similar equipment
EN 61547:2009	Equipment for general lighting purposes. EMC immunity requirements
EN 61000-3-2:2014	Electromagnetic compatibility (EMC). Limits. Limits for harmonic current emissions (equipment input current up to and including 16 A per phase) Class A
EN 61000-3-3:2008	Electromagnetic compatibility (EMC). Limits. Limitation of voltage changes, voltage fluctuations and flicker in public low-voltage supply systems, for equipment with rated current ≤ 16 A per phase and not subject to conditional connection

Artificial Optical Radiation Directive (AORD) 2006/25/EC:

EN 62471:2008 Photobiological safety of lamps and lamp systems

Restriction of the Use of Certain Hazardous Substances in Electrical and Electronic Equipment Directive (RoHS2) 2011/65/EU:

These product(s) do not contain any of the following substances, or they contain trace amounts below allowable or measurable levels in each component or mechanically separable part:

Lead (Pb), Mercury(Hg), Cadmium (Cd), Hexavalent Chromium (Cr6+), Polybrominated Biphenyls (PBB), Polybrominated Diphenyl Ether (PBDE)

Informational notes: The product(s) named herein have been found to comply with the testing and marking requirements of Australia and New Zealand and are suitable for importation into those countries.

To ensure Compliance of this product with the stated Directives it must be installed and operated for its intended use according to the manufacturer's instructions

Saint-Denis, France

(Place of issue)

M. LIABEU Nicolas

(Name of authorised person)

11th Jan 2021

(Date of Issue)

(Signature of authorised person)

Printed 2 March 2021
Previous issue: 10th July 2017

Page 1 of 1
Filename: HES Solaframe Theatre luminaire
CE DoFC 216

Declaration:
216 C

Zone Urbaparc - Bâtiment E | 6 Boulevard de la Libération | 93200 Saint-Denis | +33 (0)1 42 43 35 35 | etconnect.com
Electronic Theatre Controls France SAS | SAS au capital de 10.000 EUR | Siège social: 4, rue Marivaux, 75002 Paris | 822 232 773 RCS Paris



UK DECLARATION OF CONFORMITY



We, Electronic Theatre Controls Limited

declare under sole responsibility that the product(s):

Product series: High End Systems Sola LED luminaire

Product type/model: SolaFrame Theatre

to which this declaration relates is/are in conformity with the following Directives by the application of the quoted Standards.

Low Voltage Directive (LVD) 2014/35/EU:

EN 60598-1:2015	Luminaires. General requirements and tests
EN 60598-2-17:1989	Luminaires. Particular requirements. Specification for luminaires for stage lighting, television, film and photographic studios (outside and indoor)
EN 62471:2008	Photobiological safety of lamps and lamp systems
EN 61347-1:2015	Lamp controlgear. General and safety requirements
EN 61347-2-13:2014	Lamp controlgear. Particular requirements for d.c. or a.c. supplied electronic controlgear for LED modules

Electromagnetic Compatibility Directive (EMCD) 2014/30/EU:

EN 55015:2013+A1:2015	Limits and methods of measurement of radio disturbance characteristics of electrical lighting and similar equipment
EN 61547:2009	Equipment for general lighting purposes. EMC immunity requirements
EN 61000-3-2:2014	Electromagnetic compatibility (EMC). Limits. Limits for harmonic current emissions (equipment input current up to and including 16 A per phase) Class A
EN 61000-3-3:2008	Electromagnetic compatibility (EMC). Limits. Limitation of voltage changes, voltage fluctuations and flicker in public low-voltage supply systems, for equipment with rated current ≤ 16 A per phase and not subject to conditional connection

Artificial Optical Radiation Directive (AORD) 2006/25/EC:

EN 62471:2008	Photobiological safety of lamps and lamp systems
---------------	--

Restriction of the Use of Certain Hazardous Substances in Electrical and Electronic Equipment Directive (RoHS2) 2011/65/EU:

These product(s) do not contain any of the following substances, or they contain trace amounts below allowable or measurable levels in each component or mechanically separable part:

Lead (Pb), Mercury(Hg), Cadmium (Cd), Hexavalent Chromium (Cr6+), Polybrominated Biphenyls (PBB), Polybrominated Diphenyl Ether (PBDE)

London, United Kingdom
(Place of issue)

11th Jan 2021
(Date of Issue)

Printed 2 March 2021
Previous issue: 10th July 2017

Mr. Adam Bennette
(Name of authorised person)

(Signature of authorised person)

Page 1 of 1

Filename: HES Solaframe Theatre luminaire
UK DoC 216

Declaration:
216 C

Electronic Theatre Controls Ltd | Unit 26-28 Victoria Industrial Estate | Victoria Road | London W3 6UU | +44 (0) 208 896 1000
etconnect.com | Registered in England No. 3057796 | VAT No. GB 662 9487 90



Corporate Headquarters ■ Middleton, WI, USA | +1 608 831 4116
Global Offices ■ London, UK | Rome, IT | Holzkirchen, DE | Paris, FR | Hong Kong | Dubai, UAE | Singapore
New York, NY | Orlando, FL | Los Angeles, CA | Austin, TX
Web etcconnect.com | **Support** support.etcconnect.com | **Contact** etcconnect.com/contactETC
© 2021 Electronic Theatre Controls, Inc. | Trademark and patent info: etcconnect.com/ip
Product information and specifications subject to change. ETC intends this document to be provided in its entirety.
H730-MANL-1.2.10 Rev A Released 2021-07