



# Response 0-10V Gateway Setup Guide

Part Number: 4267M2260 Rev: B  
Released: 2020-12

To view a list of ETC trademarks and patents, go to [etconnect.com/ip](https://etconnect.com/ip). All other trademarks, both marked and not marked, are the property of their respective owners.

ETC intends this document, whether printed or electronic, to be provided in its entirety.

# Overview

The Response 0-10V Gateway is a UL924 listed network data distribution device for lighting systems that supports Net3 protocols including sACN, and DMX. It mounts to standard 35mm symmetric DIN rail.

The 0-10V Gateway provides control for up to 24 channels of 0-10V output, each supporting voltage sink connections of 400mA maximum current. Ideal for 0-10V LED driver control and four wire fluorescent fixtures, this controller converts an incoming sACN or DMX signal to 24 independently controllable 0-10V sink channels. Configuration of the gateway is done locally from the front panel or remotely from the Net3 Concert software provided by ETC.



**Note:** *The gateway must be running software v3.0.0 or later to support remote configuration using Concert.*

---



**Note:** *Network wiring should be installed and terminated by a qualified network installer and follow standard Ethernet wiring practice.*

---



The gateway includes a UL924 listed emergency contact input which can be used to trigger the outputs from an external contact closure. (e.g. a fire alarm system) The contact input is configurable to be either a normally closed (N/C), normally open (N/O), or disabled (OFF) contact.

## IMPORTANT SAFEGUARDS

When using electrical equipment basic safety precautions should always be followed including the following:

### READ AND FOLLOW ALL SAFETY INSTRUCTIONS PRIOR TO OPERATION

- Do not use outdoors.
- Do not let power supply cords touch hot surfaces.
- Do not mount near gas or electric heaters.
- Equipment should be mounted in locations and at heights where it will not readily be subjected to tampering by unauthorized personnel.
- The use of accessory equipment not recommended by ETC may cause an unsafe condition.
- Do not use this equipment for other than intended use.

### SAVE THESE INSTRUCTIONS

## Electrical Requirements

The Response 0-10V Gateway accepts 18-24VDC power and has 24 0-10V outputs. Each output connection is labeled on the cover and each of the four header connectors accepts 12-24AWG (4 - 0.25mm<sup>2</sup>) wire. Each output supports voltage sink connections of 400mA maximum current per output.

# Installation

## Environment

The 0-10V Gateway is intended to be mounted on DIN rail inside of an appropriate enclosure, with an ambient operating temperature between 0°C and 50°C

## Installing the Gateway

The 0-10V Gateway ships with one 15" RJ45 jumper cable (ETC part# N4036), one Cat5 punch-down connector, one DMX termination kit, and one network jack with double-sided tape for adhering the jack near the gateway. Additional information on the DMX termination kits ships with the kit, or can be downloaded from ETC's website, [etcconnect.com](http://etcconnect.com).

Using DMX over Cat5 cable will require the use of an additional Cat5 termination kit which is not included. Contact ETC and request part# 4100A1013.

### *To install the gateway:*

- 1: Ensure the section of DIN rail to be used is mounted securely.
- 2: Hook the top of the gateway over the top of the DIN rail as shown.
- 3: Pivot the gateway downward until it is seated securely with the two tension clips locked around the lower edge of the DIN rail.

### *To remove the gateway from the DIN rail:*

- 1: Use both thumbs to push up firmly on the bottom of the mounted gateway. This will disengage the tension clips on the rear of the gateway housing.
- 2: Rock the top of the gateway forward and off of the DIN rail.

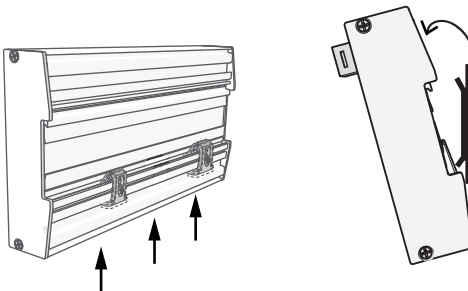
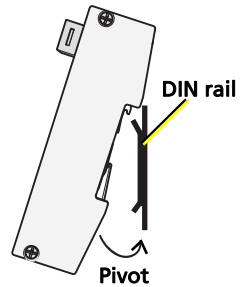

# Setup

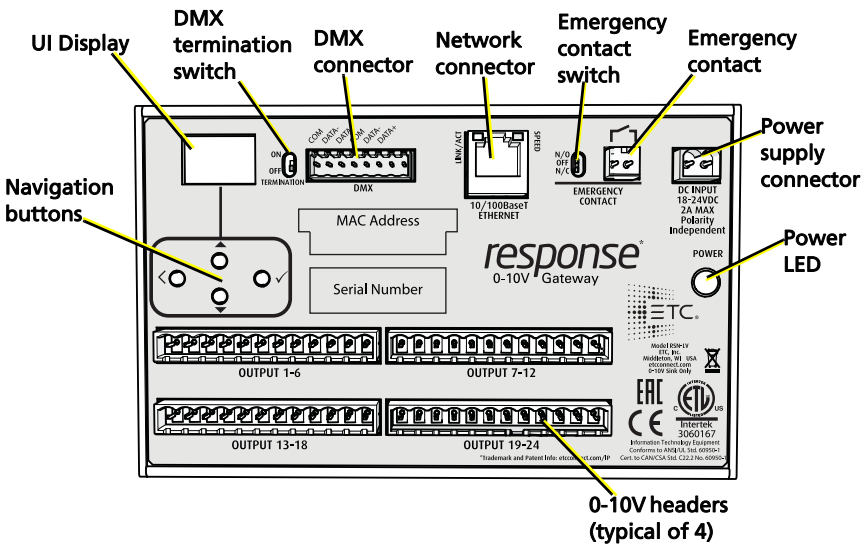

## Connectors and Buttons

- DC Power Input 18-24VDC
- Emergency Contact accepts 12-24AWG (0.2-2.5mm<sup>2</sup>) wire
- Four 0-10V headers accept 12-24AWG (0.2 - 2.5mm<sup>2</sup>)
- Combined DMX in and thru connector
- Standard RJ45 connection for
- 10/100BaseT Ethernet connection, with Link/Activity and speed indication
- Four UI buttons: up, down, enter, and back

DMX Pinout	
1	Shield In
2	DMX - In
3	DMX + In
4	Shield Thru
5	DMX - Thru
6	DMX + Thru

# Status and Feedback LEDs

When properly connected to the network, the LEDs will provide the following feedback:

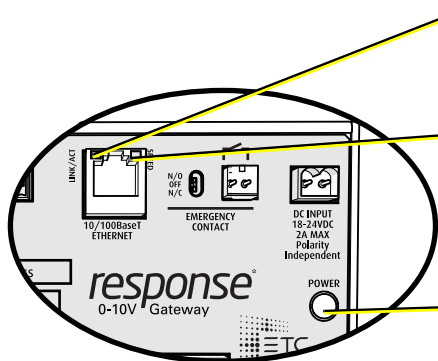

## Network Link/Activity LED

- A pulsing green LED indicates network activity.

## Speed LED

- A solid orange LED indicates connection to a 100baseT network.
- No LED indicates connection to a 10baseT network.

## Power LED

- A constant blue LED indicates power

# Emergency

The emergency contact is configured using the adjacent three-position switch. The three positions enable use of a normally open (N/O), or normally closed (N/C) contact, or disabling (OFF) of the emergency functionality.

When the emergency input is triggered any outputs set to be included will go to full. Any outputs not included will go to 0%.

# LCD Display

The 0-10V gateway includes a four line, graphical front panel display.

- Line 1: Device name
- Line 2: Device IP address
- Line 3: shows "y" if DMX or sACN is present and "n" if it is absent.
- Line 4: shows "y" if emergency input is active and "n" when not active.

0-10v Gateway 10.101.101.101 DMX:n sACN:y Emergency:y
--

# Connect Wiring

## Connect DMX

Terminate the DMX wires using the provided termination kit and plug them into the orange connector on the front of the gateway that is labeled DMX.



**Note:** *When using Belden 9729, DMX in and DMX thru use the same connector.*

## Connect sACN

- 1: Terminate the bare end of the Cat5 wire using the provided punch-down connector.
- 2: Plug one end of the provided RJ45 cable into the punch-down connector.
- 3: Plug the second end of the provided RJ45 connector into the RJ45 connector on the 0-10v Gateway.



**Note:** *A piece of double sided tape has been provided for adhering the included Cat5 punch-down connector near the gateway.*

## Terminate Load Wires

- 1: Strip the insulation from each wire pair back 1/4" (6mm).
- 2: Remove a green termination block from the connector.
- 3: Notice each connector is labeled for your wire termination reference. Using a 1/8" (3mm) flat blade screwdriver, loosen the terminals and insert each of the data + and data - wire set into the appropriate terminal for the circuit.
  - a: Terminate the positive (typically purple) control wire of the first pair into the + terminal associated with the power circuit.
  - b: Terminate the negative (typically grey) control wire of the first pair into the - terminal associated with the power circuit.

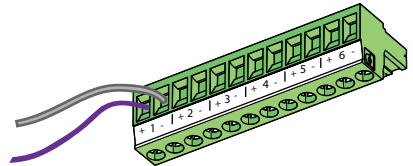

**Note:** *This connection is polarity dependant. All 24 "-" (common) terminals are tied together.*

- c: Tighten each screw terminal until the wire is securely held.
- 4: Repeat steps 1-3 for the remaining 0-10V outputs.

# Configuration

About  
Setup  
Operations

After the gateway has been securely mounted, each port can be assigned using the user interface. Navigate through all menus in the same way. See [UI Map](#) on [page 9](#).

## Buttons

- Press any button to wake up the display.
- Use the check mark ✓ to advance to the next available menu, or to commit a modified selection.
- Use the back arrow < to return to the previous menu or option.
- Use the up and down arrows to navigate between lines of a menu.

## About menu

From the home screen, press the check mark ✓ once to access the main menu. Pressing the check mark a second time allows you to access the About menu. Use the up and down arrows to navigate to the desired menu.

- Version: gives the current software version of the gateway.
- Output: allows you to scroll through the current connected loads and monitor their levels and control source.

- 1: Press ✓ to navigate to the Output value.
- 2: Use the up and down arrows to scroll through the connected outputs (1-24).
- 3: Press the back arrow < twice to navigate back to the main menu.

## Setup menu

Addressing  
Network  
Outputs  
Test

From the main menu, press the up and down arrows to navigate to the Setup menu. Press ✓ to access the following options:

- **Addressing:** This menu provides the ability to map the DMX or sACN input addresses to the 0-10V outputs. You can also enable or disable the Hold Last Look setting (HLL). See [Hold Last Look](#) on [page 7](#). Use the buttons to navigate to the desired option and change values. Select DMX or sACN depending on your input type. If you select sACN, you must also enter the sACN universe.

**Sequential patching:** If "Output" is set to Start, the first 0-10V output is patched to the address listed in the corresponding DMX/sACN Addr field. Each subsequent output is patched to the next DMX or sACN address.

For example, if "Output" is set to Start and DMX Addr is set to 3, the 24 outputs on your gateway are patched to DMX 3-26.

**Individual patching:** You can also patch each individual 0-10V output to any DMX/sACN address by setting "Output" to the appropriate number and DMX/sACN Addr to the desired address.



- *Network*: Allows you to select the network mode:
  - Automatic**: The unit's IP address is retrieved from a DHCP address server
  - Manual**: The gateway has a manually set IP address, subnet mask, and gateway address.
  - Link Local**: The gateway assigns an IP address within the link local range. It can communicate with other link local devices on the same address range.



**Note:** *Changing network settings requires a device reboot. When asked to "Apply/Reboot", select "OK" to confirm settings or press the back arrow to navigate out of the menu and keep settings as they are.*

---

- **Outputs**: Allows you to set if each output should be included with emergency settings (yes or no) as well as the dimming curve (Linear, Custom, or ModSq).
- **Test**: Allows you to test individual outputs at a certain level. Options are Test Output(1-24 or All), Level (1%-100%), and Release all.



**Note:** *If any programmed settings are invalid, an "Invalid Settings" warning will be shown. The gateway will then take you back to the screen with the entry error for modification.*

---

## Hold Last Look

When all control sources are lost, output behavior is dependent on the Hold Last Look (HLL) setting.

- If "HLL" is set to On, the output will remain at whatever level it was last set to indefinitely (until the next reboot).
- If "HLL" is set to Off, the output will revert to 0V when all sources are lost.

Hold last look behavior only applies for streaming sources (i.e. DMX and sACN). Set levels and emergency do not hold last look. For example, if the emergency look is activated and no other sources are present, when emergency is deactivated, outputs go to zero.

## Operations menu

Restore Defaults  
Update Software

- *Restore defaults.* You will be prompted to: Restore Defaults, All data will be lost. Select "OK" or press the back arrow to return to previous menu option.
- *Update software.* If your network is configured with an ETC update server (such as ETC Net3 Conductor or an ETC console), you can trigger a firmware update from the user interface. The latest software will be downloaded from the server.

## Firmware updates

This device can be field upgraded to the latest firmware. ETC recommends that you only perform firmware updates if you require a specific feature of new firmware. If you are uncertain of the proper steps to perform a firmware upgrade, contact ETC.



---

**Note:** *Never perform firmware updates during a live event situation or when under time restrictions.*

---

*Update the gateway in one of the following ways:*

- Use a PC running ETC's UpdaterAtoR software. Visit the ETC website [www.etconnect.com](http://www.etconnect.com) to download UpdaterAtoR. Operation instructions are included with the software.
- Use a console or Net3 Conductor running Net3 Services with the latest firmware on the server. Use the front panel to trigger the update from the Operations Menu. See [Operations menu](#) on [page 8](#).

# Troubleshooting

Problem	Solution
Display blank, blue power LED not illuminated	Check incoming power is 18-24DC and is correctly connected
Display blank, blue power LED illuminated	Display is in "sleep" state. Press any button to wake the display.
Outputs do not come on	<ul style="list-style-type: none"> <li>• Check that the outputs are correctly connected with appropriate polarity (See <a href="#">Terminate Load Wires</a> on <a href="#">page 5</a>).</li> <li>• Check data input is correctly connected (See <a href="#">Connect Wiring</a> on <a href="#">page 5</a>).</li> <li>• Check the front display shows "DMX:y" or "sACN:y" appropriately for the control sources.</li> <li>• Check that the controlling device is sending levels using protocol test tools. for example, a DMX test tool or sACN viewer.</li> <li>• Follow the troubleshooting steps in ETC's 0-10V application note available from <a href="http://etconnect.com">etconnect.com</a></li> </ul>

## UI Map

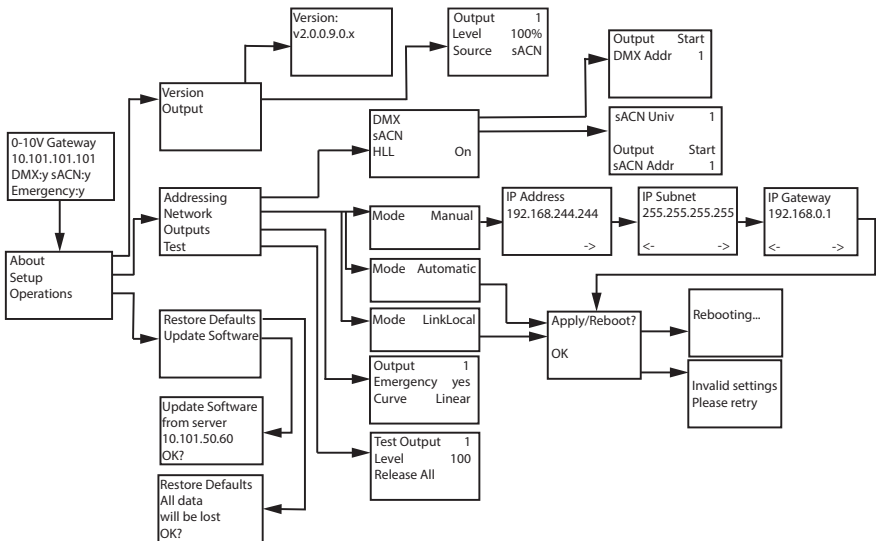



**Corporate Headquarters** Middleton, WI, USA +1 608 831 4116  
**London, UK** +44 (0)20 8896 1000 **Holzkirchen, DE** +49 (80 24) 47 00-0  
**Rome, IT** +39 (06) 32 111 683 **Hong Kong** +852 2799 1220 **Paris, FR** +33 1 4243 3535  
**Web** [etcconnect.com](http://etcconnect.com) **Support** [support.etcconnect.com](http://support.etcconnect.com) **Contact** [etcconnect.com/contact](http://etcconnect.com/contact)  
© 2020 Electronic Theatre Controls, Inc.  
Product information and specifications subject to change. ETC intends this document to be provided in its entirety. Trademark and patent info: [etcconnect.com/ip](http://etcconnect.com/ip)  
**4267M2260** Rev B Released 2020-12