

Type(s)

Project

Date

Notes



**GENERAL INFORMATION**

The Source 4WRD PAR and PARNeI Fixture Bodies allow you to transform your Source 4WRD II LED into a beautiful softlight. Taking advantage of the great energy efficiency, cool operating temperatures, DMX dimming or line voltage dimming and no lamp changes, the Source 4WRD PAR and PARNeI deliver amazing output without compromise.

**APPLICATIONS**

- Houses of worship
- Universities and schools
- Hospitality
- Retail
- Exhibition centers
- Meeting rooms
- Clubs
- Cafeteriums

**PRODUCT FEATURES**

- Fixture bodies for use with Source 4WRD II LED Retrofit
- Works just like a Source Four PAR or PARNeI, using the same accessories
- 155 W at full output
- Brighter than the 750 W HPL versions
- Uses same Source 4WRD II LED as the Source 4WRD ellipsoidal

**ORDERING INFORMATION**

**S4WRD PAR and PARNeI Fixture Bodies**

MODEL	PART NUMBER	DESCRIPTION	
S4WRDPAR	7067A1109	Source 4WRD PAR Fixture Body, Black	
S4WRDPARNeI	7067A1110	Source 4WRD PARNeI Fixture Body, Black	

Color Options: Fixture body ships standard in black. For additional colors please use the color code suffix: Add -1 for white or -5 for silver

Note: Source 4WRD II LED and c-clamp sold separately.

**SOURCE 4WRD PAR AND PARNeI FIXTURE BODIES SHIP WITH:**

- Color frame
- PAR ships with AR coated flat lens (other lenses sold separately)
- PARNeI ships with PARNeI lenses



## PRODUCT SPECIFICATIONS

## Source

LED details	S4WRD II LED *Not Included*
Max lumens	11,584 (PAR), 10,786 (PARNeI) w/ S4WRD II
Lumens per watt	77 (PAR), 72 (PARNeI)
L70 rating (hours to 70% output)	>45,000 hours (LM84 test pending)
Notes	S4WRD II LED sold separately

## Color

Colors used	Warm or Cool White
Color temperature range	3200 K 80 or 90+ CRI, 5900 K 90+ CRI
Calibrated array	NA
Red shift	No
Notes	S4WRD is available in 80+ CRI (Standard) and 90+ CRI (Gallery) - See S4WRD datasheet for details

## Optical

Beam angle range	PAR: 10–36° PARNeI: 13–30°
Gate size	N/A
Aperture size	178 mm (7 in)
Pattern projection	No
Pattern size	N/A
Camera flicker control/Hz range	No
Notes	PAR ships with an AR coated flat lens. Additional PAR lenses sold separately. PARNeI ships with PARNeI lenses.

## Control

Input method	Line Voltage with DMX Control or Line Dimmed
Protocols	DMX via RJ45 connector
Modes (Footprint)	1
RDM configuration	Yes
UI type	7-segment address display
Local control	Yes
Onboard presets	No
Onboard sequences	No
Onboard effects	No
Fixture to fixture control	No
Notes	Local level control via UI

## Electrical

Voltage range	114–125 V, 60 Hz (120 VAC) 209–252 V, 50 Hz (230 VAC)
Input method	Hard wired, 1 m cord, Edison plug (120 VAC) Hard wired, 1 m cord, bare end (230 VAC)
Inrush	30 A (first half-cycle) at 120 VAC 12 A (first half-cycle) at 230 VAC
Fixtures per circuit*	120 VAC: 14 fixtures per 20 A switched circuit (R20 module or similar) 230 VAC: 6 fixtures per non-dimmed circuit (ER15AFR module)
Wattage (Typical/Standby)	150 W / 1.2 W (120 VAC) 175 W / 3.7 W (230 VAC)
Current draw	1.26 A at 120 VAC 0.75 A at 230 VAC
Notes	- When using line dimming, see the S4WRD manual for dimmer setup. - When using line dimming, standby power is 0 W.

\*All measurements are for 120 V, 60 Hz. Results may vary in different regions.

## Thermal

Ambient operating temp	5°–50° C (41°–122° F)
Fan (controllable)	Yes (no)
Droop compensation	No
dB range	28 dBA (average at 1 m)
BTUs/hour	529 (120 VAC) 597 (230 VAC)

## Physical

Materials	Die-cast aluminum
Color options	Black, white, silver or custom color
Mounting options	Yoke
IP rating	IP-20
Weight	PAR: 3 kg (6.6 lb) / PARNeI: 3.5 kg (7.7 lb)
Included accessories	Color frame
Notes	Includes S4WRD mounting post. Requires the S4WRD II LED available separately

## Warranty

Fixture	Three years
---------	-------------

## Regulatory and Compliance

Approved regulatory standards	cULus CE Compliant when used with ETC Source 4WRD LED Retrofit
-------------------------------	---

PRODUCT FEATURES



**BRIGHT!**  
Brighter than a 750 W fixture while using 1/5 the power



**USES YOUR EXISTING ACCESSORIES**  
Works just like a Source Four PAR and PARNel



**INTERCHANGABLE WITH S4 PROFILES**  
You can interchange your Source 4WRD II LED sources between your S4 profile fixtures and your Source 4WRD PAR and PARNel fixture bodies

COLOR METRIC INFORMATION

SOURCE 4WRD II 3200 K TM-30-18 - 80 CRI

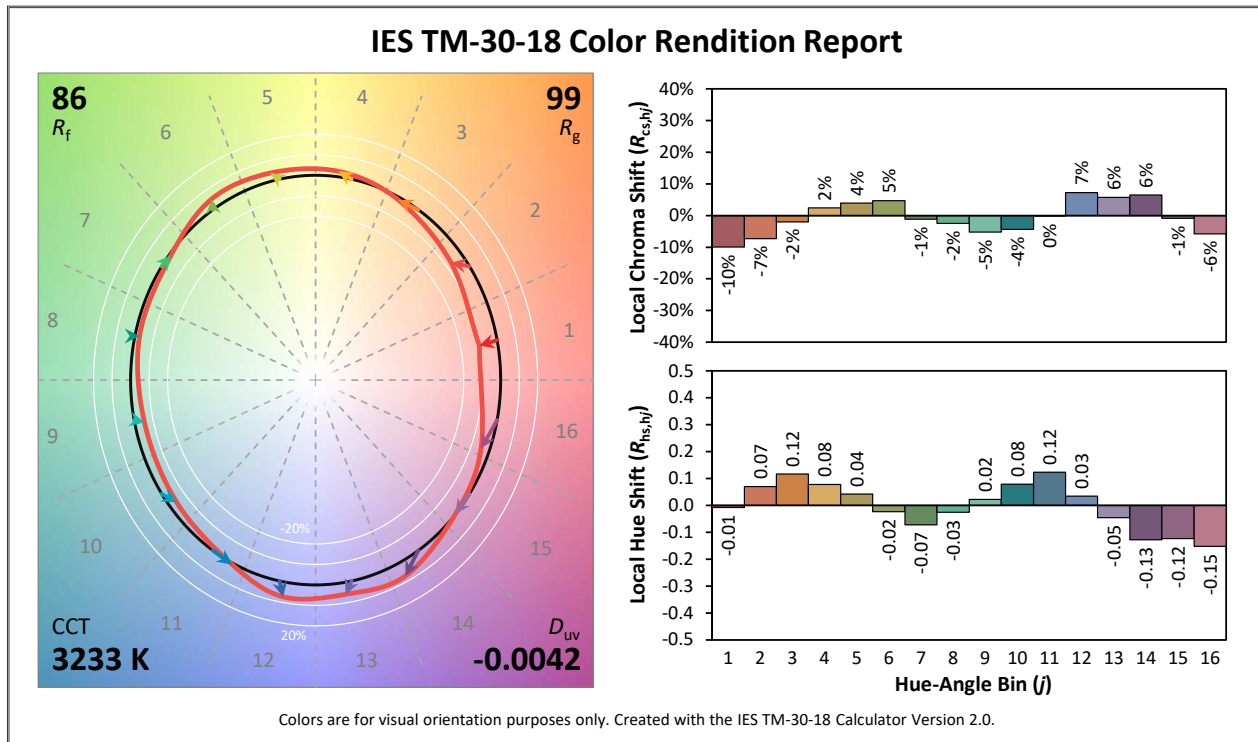

Note: The spectral layouts shown in this datasheet are designed to print so that the color vector graphic has a square aspect ratio, even though it appears rectangular on the screen. For some users, the graphic may need to be adjusted so that it prints square.

COLOR METRIC INFORMATION

SOURCE 4WRD II GALLERY 3200 K 90 CRI

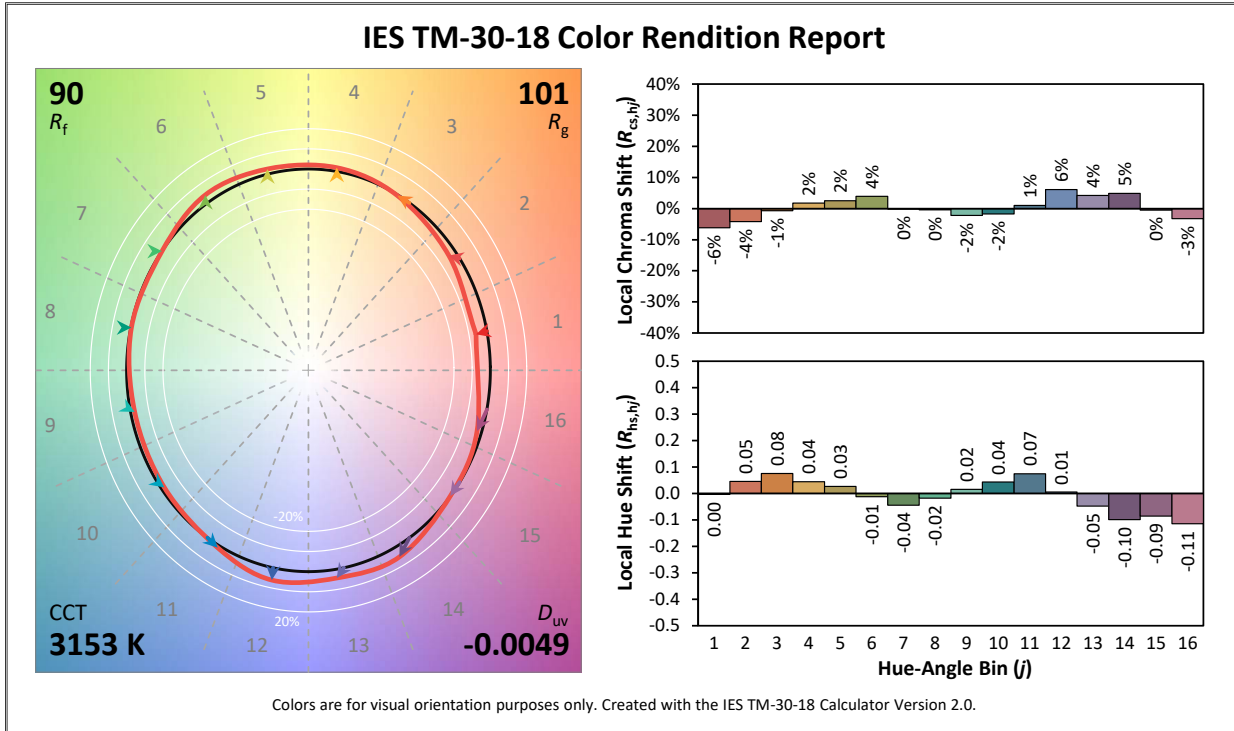

SOURCE 4WRD II DAYLIGHT GALLERY 5900 K 90 CRI

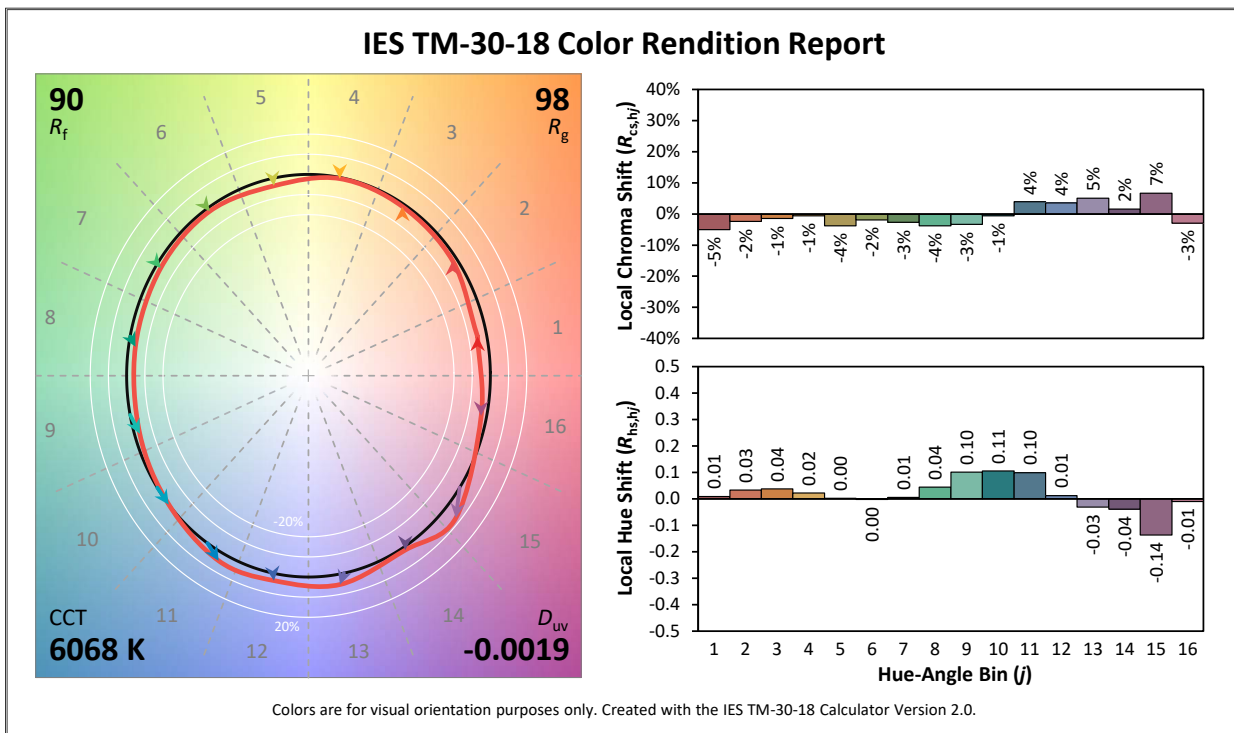

Additional Color Metrics

	STANDARD	GALLERY	DAYLIGHT GALLERY
CRI Ra (R9)	81 (9)	92 (59)	93 (73)
TLCI	66	92	95

COLOR METRIC INFORMATION

SOURCE 4WRD II PAR 3200 K TM-30-18 - 80 CRI

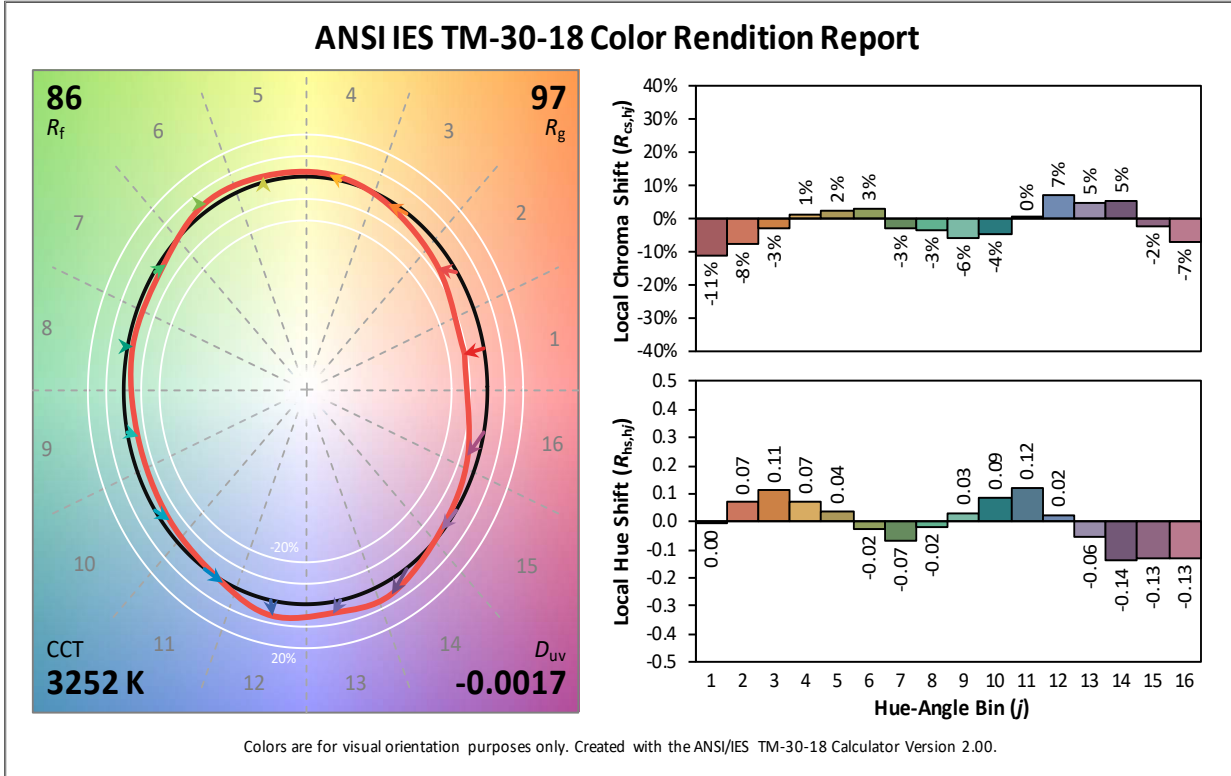

SOURCE 4WRD II PARNeI 3200 K TM-30-18 - 80 CRI

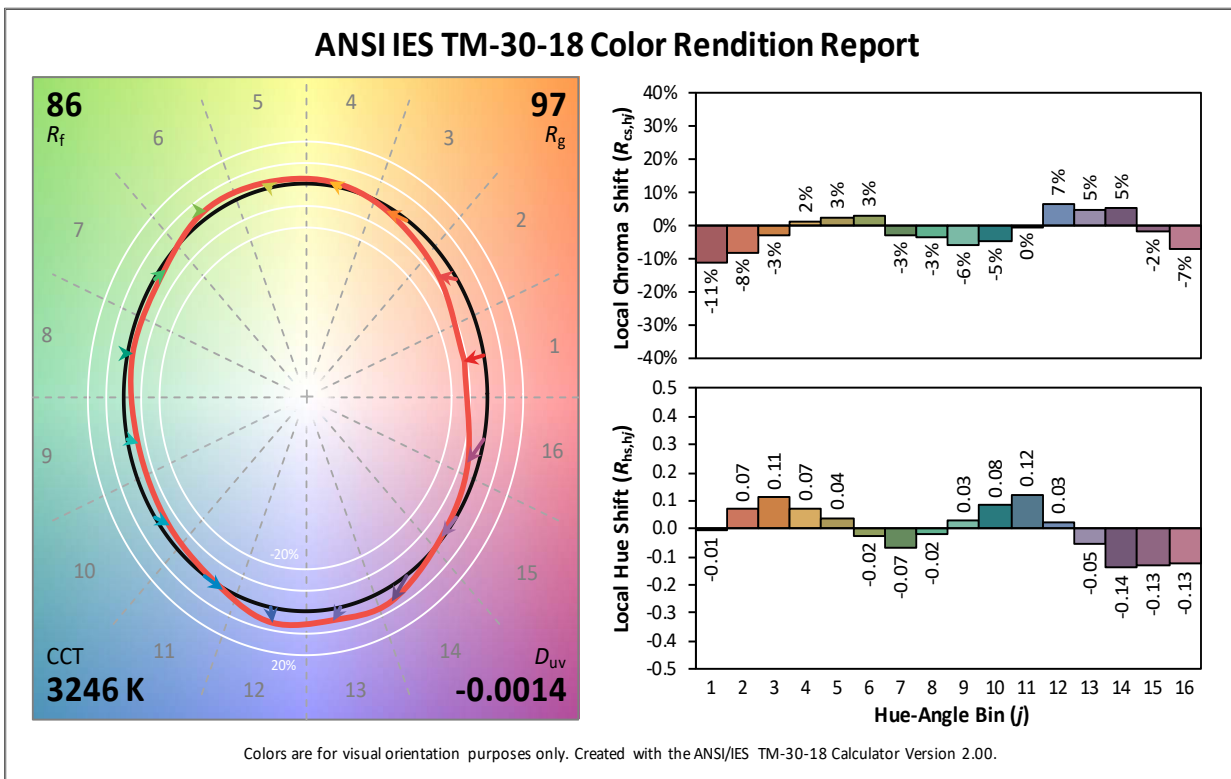

COLOR METRIC INFORMATION

SOURCE 4WRD II PAR GALLERY 3200 K TM-30-18 - 90 CRI

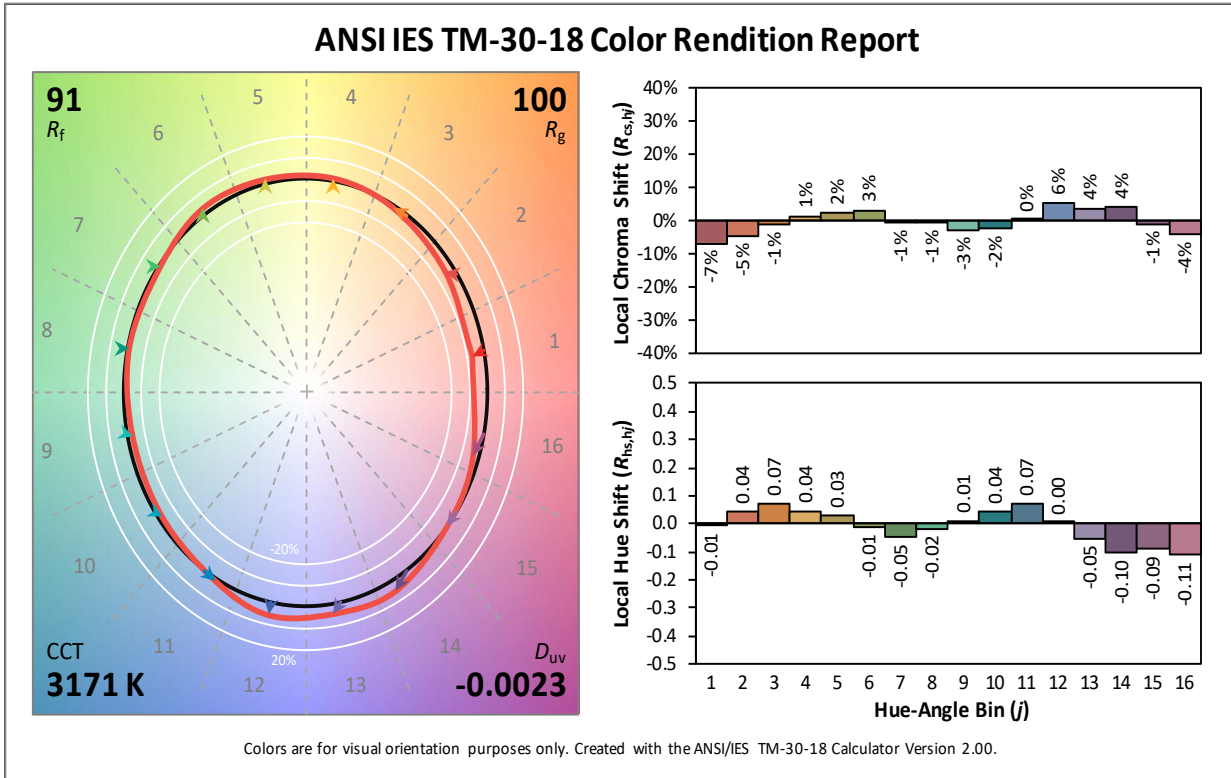

SOURCE 4WRD II PARNel GALLERY 3200 K TM-30-18 - 90 CRI

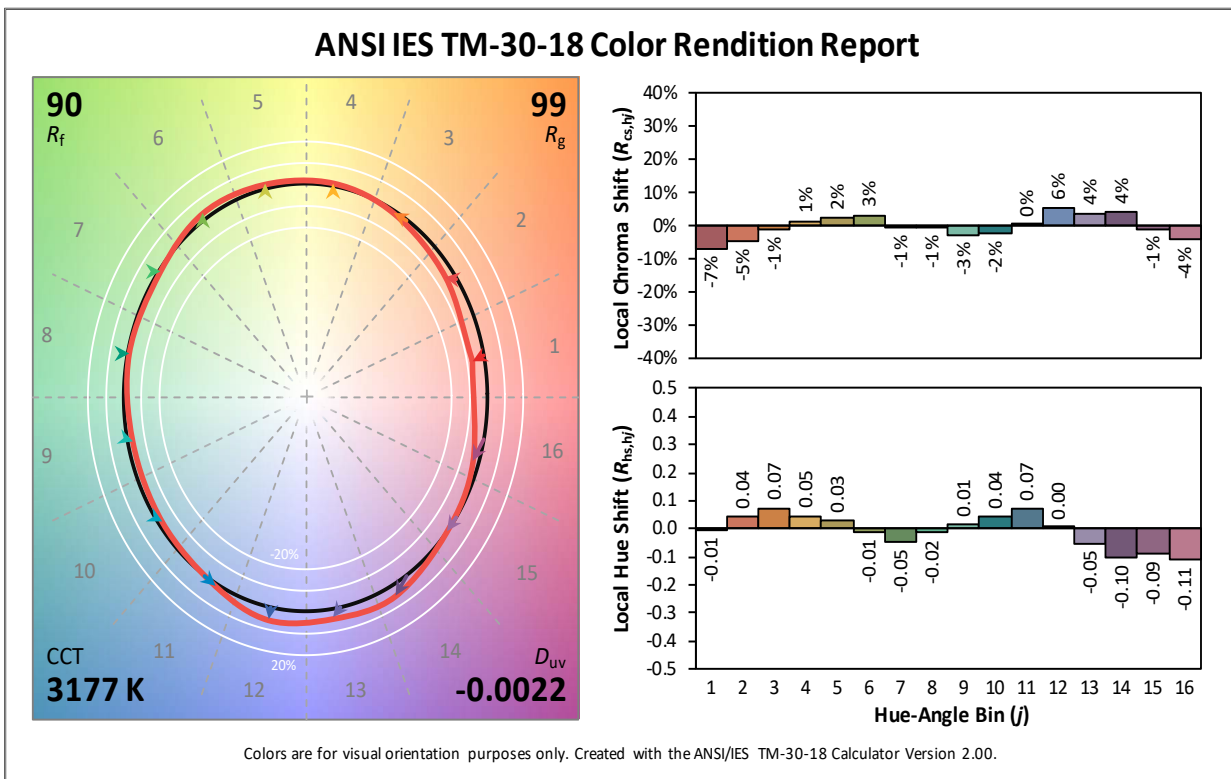

COLOR METRIC INFORMATION

SOURCE 4WRD II PAR DAYLIGHT GALLERY 5900 K TM-30-18 - 90 CRI

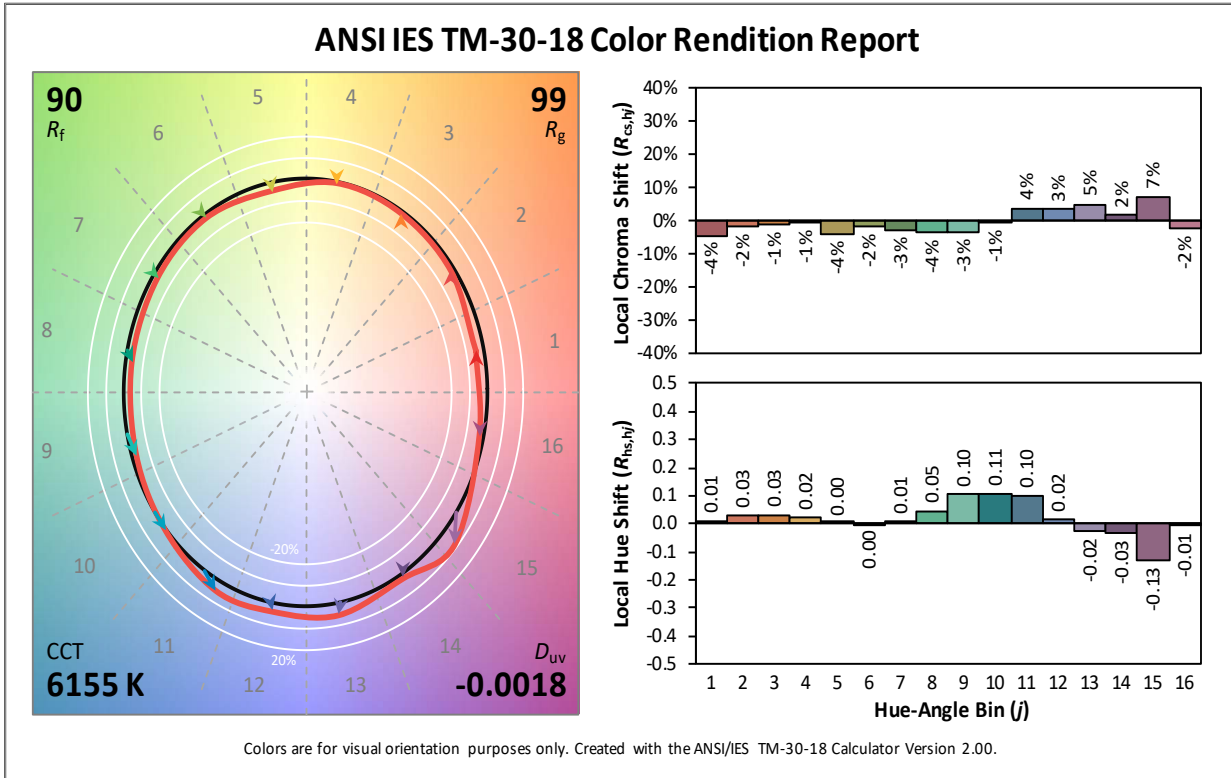

SOURCE 4WRD II PARNel DAYLIGHT GALLERY 5900 K TM-30-18 - 90 CRI

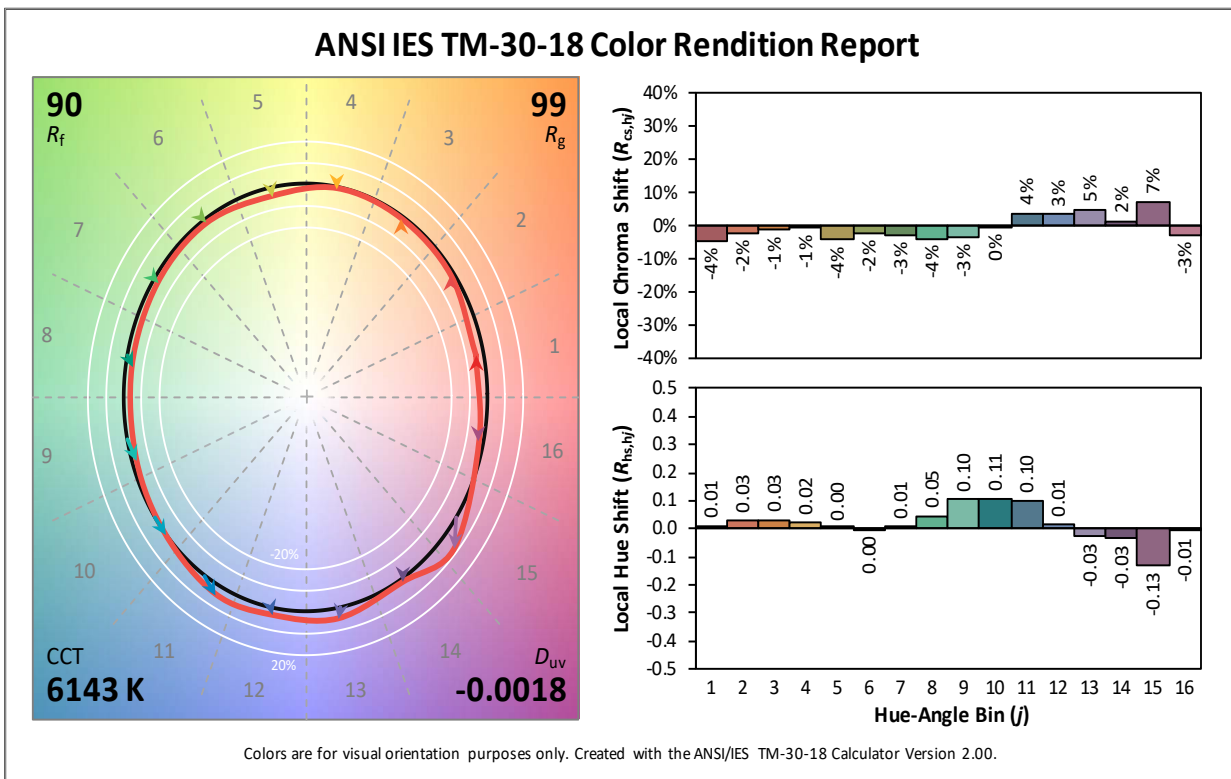

**Additional Color Metrics**

	<b>PAR STANDARD</b>	<b>PARNeI STANDARD</b>	<b>PAR GALLERY</b>	<b>PARNeI GALLERY</b>	<b>PAR DAYLIGHT GALLERY</b>	<b>PARNeI DAYLIGHT GALLERY</b>
CRI $R_a$ ( $R_g$ )	84 (11)	84 (11)	90 (43)	90 (43)	94 (76)	94 (75)
TLCI	92	66	91	65	95	95

**NOTES ABOUT LED LUMINAIRES**

All LED sources experience some lessening of light output and some color shift over time. LED output will vary with thermal conditions. Thermal conditions can be affected by ambient temperatures and orientation. Based on the LED manufacturer's B50 L70 specification, a Source 4WRD II luminaire will achieve ~70% of its initial output after 60,000+ hours of typical usage. In individual situations, LEDs will be used for different durations and at different levels. This can eventually lead to minor alterations in color performance, necessitating slight adjustments to presets, cues or programs.

**ADDITIONAL ORDERING INFORMATION****ACCESSORIES**

<b>MODEL</b>	<b>DESCRIPTION</b>
S4WRD	Source 4WRD Retrofit Kit
S4WRDGD	Source 4WRD Gallery (90+ CRI) Retrofit Kit
407CF	Color frame (7.5") (included)
400SC	Safety Cable
400CC	C-Clamp
400-VNSP	Very Narrow Spot lens
400-NSP	Narrow Spot lens
400-MFL	Medium Flood lens
400-WFL	Wide Flood lens
400-LS4	Set of four Source Four PAR lenses (VNSP, NSP, MFL, WFL)
400-XWFL	Extra Wide Flood lens
400PTH3	Top hat, 3"
400PTH6	Top hat, 6"
400PHH	Half hat
400XBTH	Cross baffle top hat
400BD	Barn door
400L	Egg crate louver
400WB	Weighted base



PHOTOMETRICS

Source 4WRD II PAR 80 CRI with AR Coated Flat Lens

Mode	Degree	Candela	Lumens (Beam, Field)	Power Consumption	Lumens Per Watt
AR Coated Flat	20.3	323,808	5,140, 11,584	149 W	77.7

Metric conversions: For meters, multiply feet by 0.3048  
For lux, multiply footcandles by 10.76

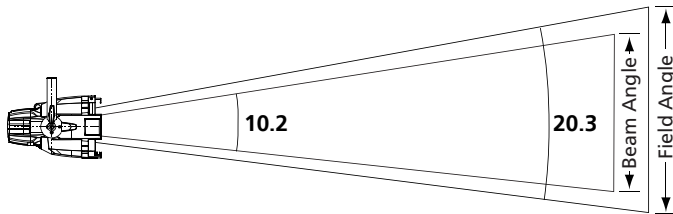

Throw Distance (d)	10 ft	15 ft	20 ft	25 ft	569 ft
	3.0 m	4.6 m	6.1 m	7.6 m	173.4 m
Field Diameter	3.6 ft	5.4 ft	7.2 ft	9.0 ft	-
	1.1 m	1.6 m	2.2 m	2.7 m	
Illuminance (fc)	3,238	1,439	810	518	1
Illuminance (lux)	34,854	15,491	8,714	5,577	10.76

To determine center beam illumination in footcandles at any throw distance, divide candela by the throw distance squared

For field diameter at any distance, multiply distance by 0.358  
For beam diameter at any distance, multiply by 0.178

Source 4WRD II PAR 80 CRI with VN5P Lens

Mode	Degree	Candela	Lumens (Beam, Field)	Power Consumption	Lumens Per Watt
VN5P	21.7	281,300	5,111, 10,938	149 W	73.4

Metric conversions: For meters, multiply feet by 0.3048  
For lux, multiply footcandles by 10.76

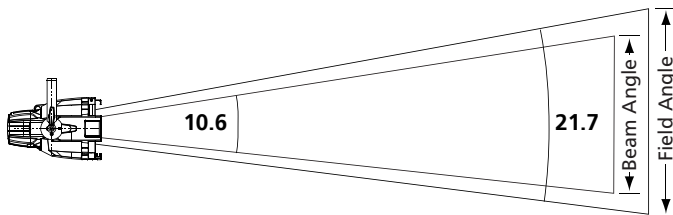

Throw Distance (d)	10 ft	15 ft	20 ft	25 ft	530.4 ft
	3.0 m	4.6 m	6.1 m	7.6 m	161.7 m
Field Diameter	3.8 ft	5.7 ft	7.7 ft	9.6 ft	-
	1.2 m	1.8 m	2.3 m	2.9 m	
Illuminance (fc)	2,813	1,250	703	450	1
Illuminance (lux)	30,279	13,457	7,570	4,845	10.76

To determine center beam illumination in footcandles at any throw distance, divide candela by the throw distance squared

For field diameter at any distance, multiply distance by 0.383  
For beam diameter at any distance, multiply by 0.186

Candela Plot

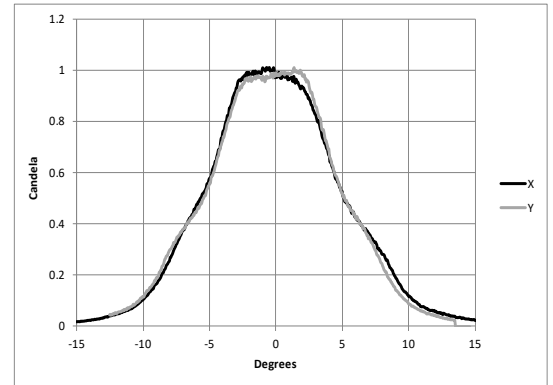

Iso-Illuminance Diagram

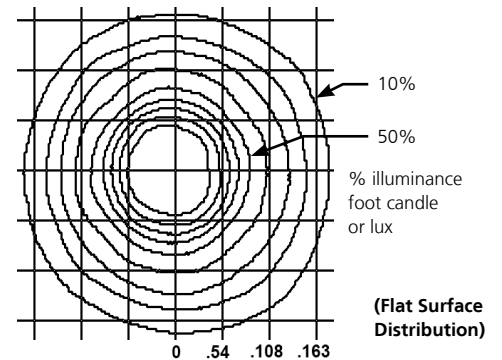

Candela Plot

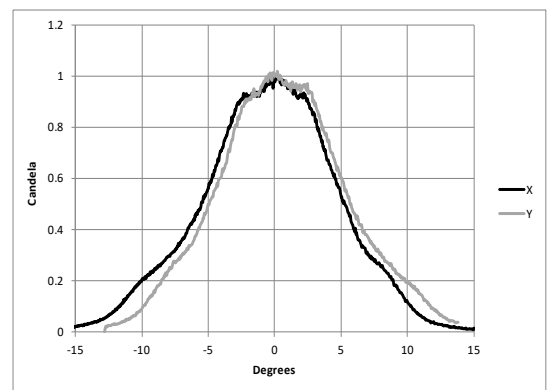

Iso-Illuminance Diagram

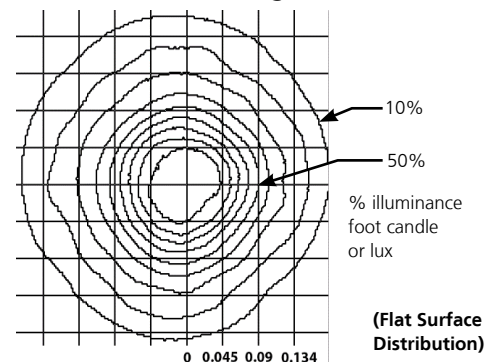

PHOTOMETRICS

Source 4WRD II PAR 80 CRI with NSP Lens

Mode	Degree	Candela	Lumens (Beam, Field)	Power Consumption	Lumens Per Watt
NSP	22.8	239,300	5,349, 10,779	149 W	72.3

Metric conversions: For meters, multiply feet by 0.3048  
For lux, multiply footcandles by 10.76

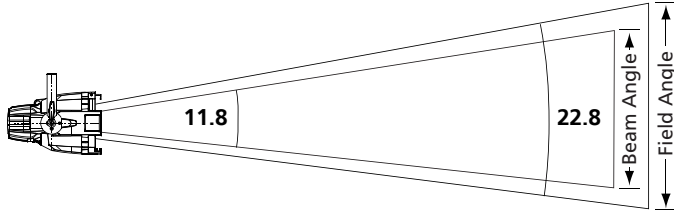

Throw Distance (d)	10 ft	15 ft	20 ft	25 ft	489.2 ft
	3.0 m	4.6 m	6.1 m	7.6 m	149.1 m
Field Diameter	4.0 ft	6.0 ft	8.1 ft	10.1 ft	-
	1.2 m	1.8 m	2.5 m	3.1 m	-
Illuminance (fc)	2,393	1,064	598	383	1
Illuminance (lux)	25,758	11,448	6,440	4,121	10.76

To determine center beam illumination in footcandles at any throw distance, divide candela by the throw distance squared

For field diameter at any distance, multiply distance by 0.403  
For beam diameter at any distance, multiply by 0.207

Candela Plot

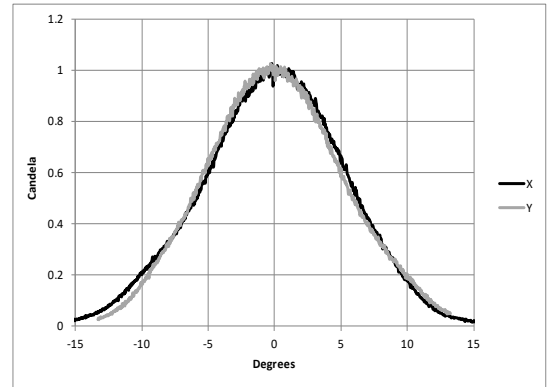

Iso-Illuminance Diagram

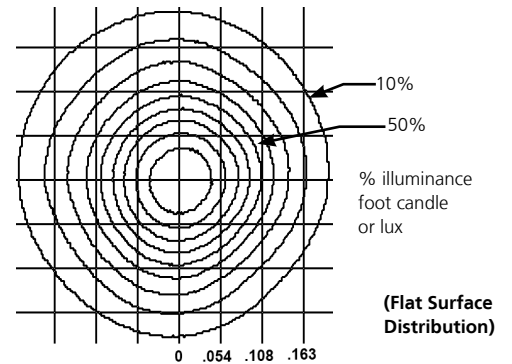

Source 4WRD II PAR 80 CRI with MFL Lens

Mode	Degree	Candela	Lumens (Beam, Field)	Power Consumption	Lumens Per Watt
MFL	35.5 Horizontal (H) 27.4 Vertical (V)	109,900	6,387, 10,829	149 W	72.7

Metric conversions: For meters, multiply feet by 0.3048  
For lux, multiply footcandles by 10.76

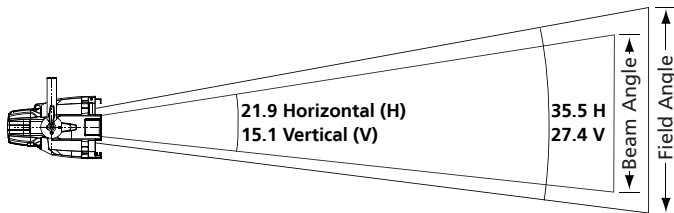

Throw Distance (d)	10 ft	15 ft	20 ft	25 ft	331.5 ft
	3.0 m	4.6 m	6.1 m	7.6 m	101 m
Field Diameter	6.4 ft	9.6 ft	12.8 ft	16 ft	-
	2.0 m	2.9 m	3.9 m	4.9 m	-
Illuminance (fc)	1,099	488	275	176	1
Illuminance (lux)	11,830	5,258	2,957	1,893	10.76

To determine center beam illumination in footcandles at any throw distance, divide candela by the throw distance squared

For field diameter at any distance, multiply distance by 0.640  
For field height at any distance, multiply distance by 0.488  
For beam diameter at any distance, multiply by 0.387  
For beam height at any distance, multiply by 0.265

Candela Plot

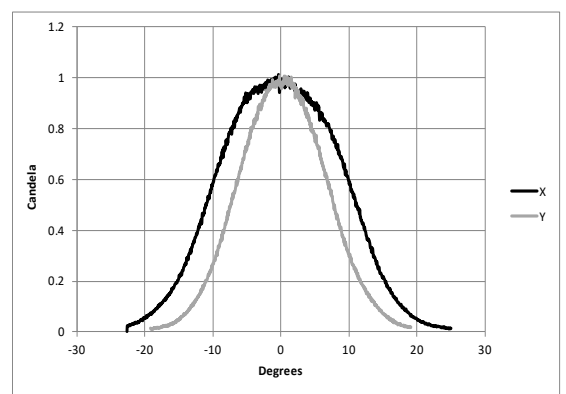

Iso-Illuminance Diagram

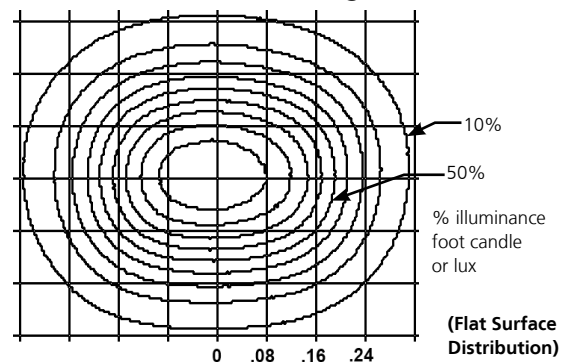

PHOTOMETRICS

Source 4WRD II PAR 80 CRI with WFL Lens

Mode	Degree	Candela	Lumens (Beam, Field)	Power Consumption	Lumens Per Watt
WFL	55.0 Horizontal (H) 40.0 Vertical (V)	41,300	6,554, 10,705	149 W	71.8

Metric conversions: For meters, multiply feet by 0.3048  
For lux, multiply footcandles by 10.76

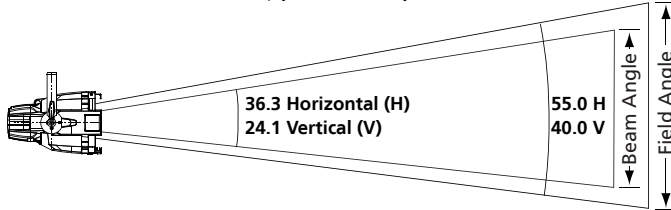

Throw Distance (d)	10 ft	15 ft	20 ft	25 ft	203.2 ft
	3.0 m	4.6 m	6.1 m	7.6 m	61.9 m
Field Diameter	10.4 ft	15.6 ft	20.8 ft	26.0 ft	-
	3.2 m	4.8 m	6.3 m	7.9 m	
Illuminance (fc)	413	184	103	66	1
Illuminance (lux)	4,445	1,976	1,111	711	10.76

To determine center beam illumination in footcandles at any throw distance, divide candela by the throw distance squared

For field diameter at any distance, multiply distance by 1.041  
For field height at any distance, multiply distance by 0.728  
For beam diameter at any distance, multiply by 0.656  
For beam height at any distance, multiply by 0.427

Candela Plot

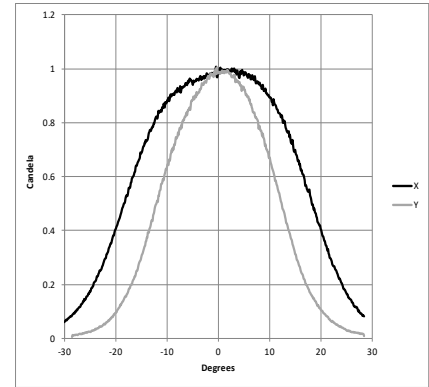

Iso-Illuminance Diagram

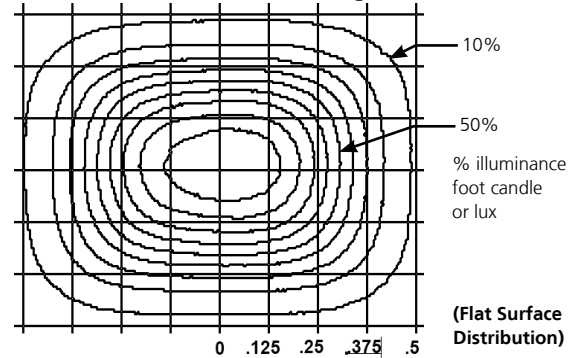

Source 4WRD II PAR 80 CRI with XWFL Lens

Mode	Degree	Candela	Lumens (Beam, Field)	Power Consumption	Lumens Per Watt
XWFL	62.5	24,900	3,037, 7,384	149 W	49.6

Metric conversions: For meters, multiply feet by 0.3048  
For lux, multiply footcandles by 10.76

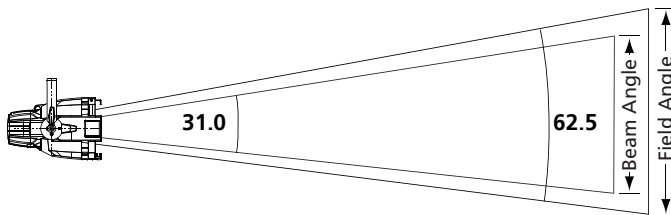

Throw Distance (d)	10 ft	15 ft	20 ft	25 ft	157.8 ft
	3.0 m	4.6 m	6.1 m	7.6 m	48.1 m
Field Diameter	12.1ft	18.2 ft	24.3 ft	30.3 ft	-
	3.7m	5.5 m	7.4 m	9.2 m	
Illuminance (fc)	249	111	62	40	1
Illuminance (lux)	2,680	1,191	670	429	10.76

To determine center beam illumination in footcandles at any throw distance, divide candela by the throw distance squared

For field diameter at any distance, multiply distance by 1.214  
For beam diameter at any distance, multiply by 0.555

Candela Plot

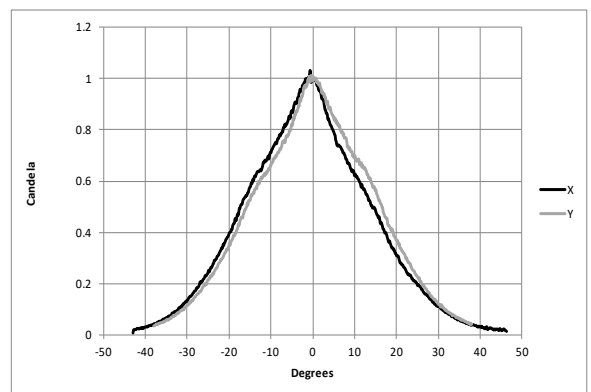

Iso-Illuminance Diagram

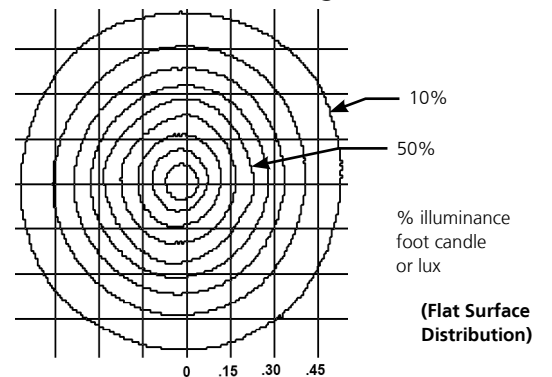

PHOTOMETRICS

Source 4WRD II PARNel 80 CRI Spot

Mode	Degree	Candela	Lumens (Beam, Field)	Power Consumption	Lumens Per Watt
PARNel 80 CRI Spot	25.5	174,983	4,618, 9,354	149 W	62.8

Metric conversions: For meters, multiply feet by 0.3048  
For lux, multiply footcandles by 10.76

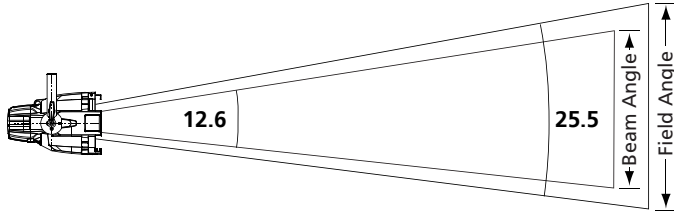

Throw Distance (d)	10 ft 3.0 m	15 ft 4.6 m	20 ft 6.1 m	25 ft 7.6 m	418.3 ft 127.5 m
Field Diameter	4.5 ft 1.4 m	6.8 ft 2.1 m	9.1 ft 2.8 m	11.3 ft 3.4 m	-
Illuminance (fc)	1,750	778	437	280	1
Illuminance (lux)	18,835	8,371	4,709	3,014	10.76

To determine center beam illumination in footcandles at any throw distance, divide candela by the throw distance squared

For field diameter at any distance, multiply distance by 0.453  
For beam diameter at any distance, multiply by 0.221

Source 4WRD II PARNel 80 CRI Flood

Mode	Degree	Candela	Lumens (Total, Beam, Field)	Power Consumption	Lumens Per Watt
PARNel 80 CRI Flood	43.8	49,456	7,309, 10,786	149 W	72.4

Metric conversions: For meters, multiply feet by 0.3048  
For lux, multiply footcandles by 10.76

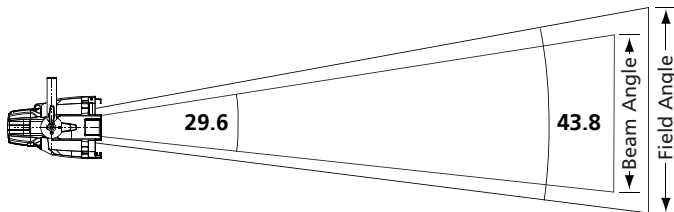

Throw Distance (d)	10 ft 3.0 m	15 ft 4.6 m	20 ft 6.1 m	25 ft 7.6 m	222.4 ft 67.8 m
Field Diameter	8.0 ft 2.5 m	12.1 ft 3.7 m	16.1 ft 4.9 m	20.1 ft 6.1 m	-
Illuminance (fc)	495	220	124	79	1
Illuminance (lux)	5,323	2,366	1,331	852	10.76

To determine center beam illumination in footcandles at any throw distance, divide candela by the throw distance squared

For field diameter at any distance, multiply distance by 0.804  
For beam diameter at any distance, multiply by 0.528

Candela Plot

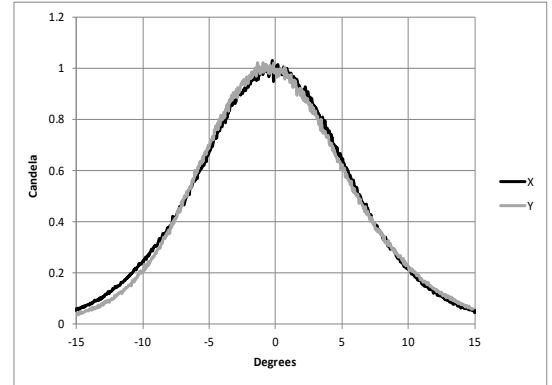

Iso-Illuminance Diagram

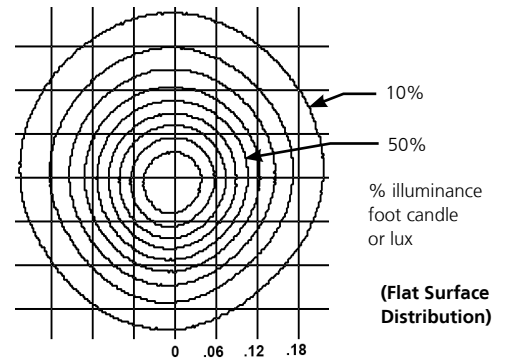

Candela Plot

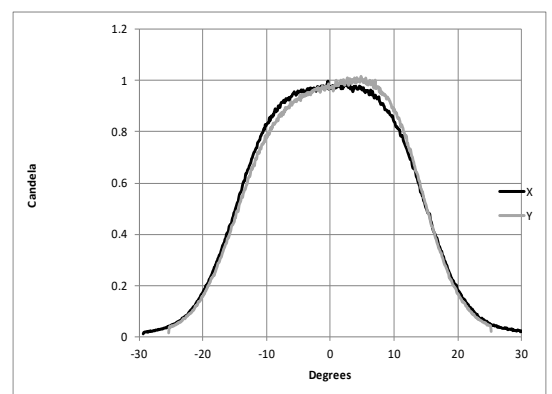

Iso-Illuminance Diagram

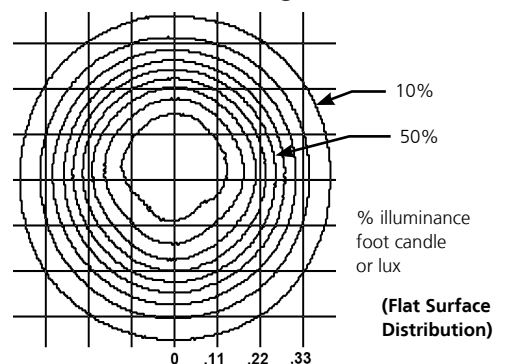

PHOTOMETRICS

Source 4WRD II PAR Gallery 90 CRI with AR Coated Flat Lens

Mode	Degree	Candela	Lumens (Beam, Field)	Power Consumption	Lumens Per Watt
AR Coated Flat	20.3	260,988	4,618, 9,486	149 W	63.7

Metric conversions: For meters, multiply feet by 0.3048  
For lux, multiply footcandles by 10.76

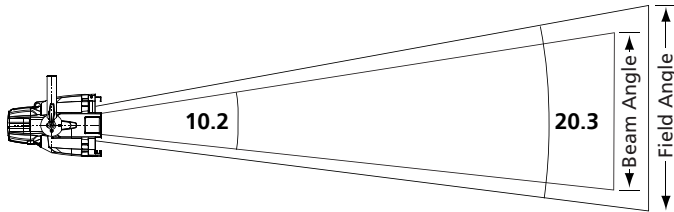

Throw Distance (d)	10 ft	15 ft	20 ft	25 ft	569 ft
	3.0 m	4.6 m	6.1 m	7.6 m	173.4 m
Field Diameter	3.6 ft	5.4 ft	7.2 ft	9.0 ft	-
	1.1 m	1.6 m	2.2 m	2.7 m	
Illuminance (fc)	3,238	1,439	810	518	1
Illuminance (lux)	34,854	15,491	8,714	5,577	10.76

To determine center beam illumination in footcandles at any throw distance, divide candela by the throw distance squared

For field diameter at any distance, multiply distance by 0.358  
For beam diameter at any distance, multiply by 0.178

Source 4WRD II PAR Gallery 90 CRI with VSNP Lens

Mode	Degree	Candela	Lumens (Beam, Field)	Power Consumption	Lumens Per Watt
VSNP	21.7	239,105	4,344, 9,297	149 W	62.4

Metric conversions: For meters, multiply feet by 0.3048  
For lux, multiply footcandles by 10.76

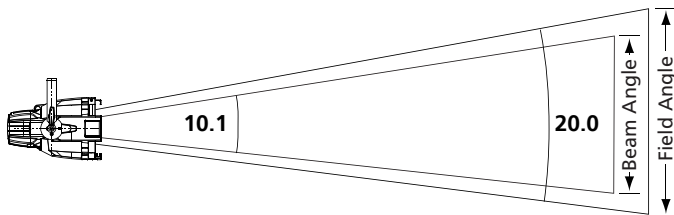

Throw Distance (d)	10 ft	15 ft	20 ft	25 ft	530.4 ft
	3.0 m	4.6 m	6.1 m	7.6 m	161.7 m
Field Diameter	3.8 ft	5.7 ft	7.7 ft	9.6 ft	-
	1.2 m	1.8 m	2.3 m	2.9 m	
Illuminance (fc)	2,813	1,250	703	450	1
Illuminance (lux)	30,279	13,457	7,570	4,845	10.76

To determine center beam illumination in footcandles at any throw distance, divide candela by the throw distance squared

For field diameter at any distance, multiply distance by 0.383  
For beam diameter at any distance, multiply by 0.186

Candela Plot

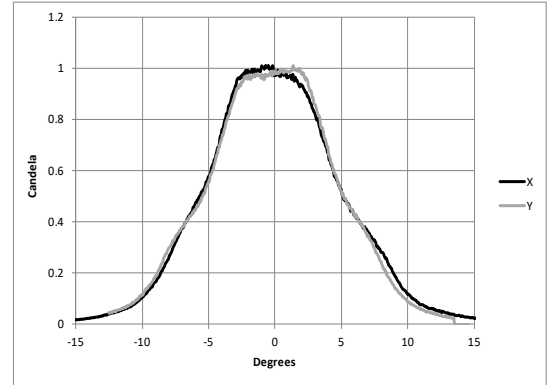

Iso-Illuminance Diagram

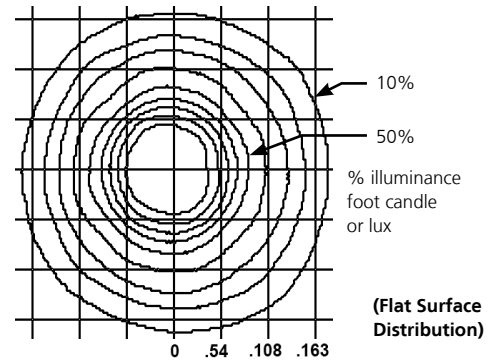

Candela Plot

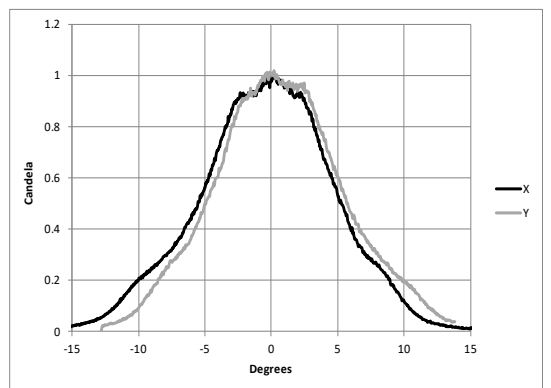

Iso-Illuminance Diagram

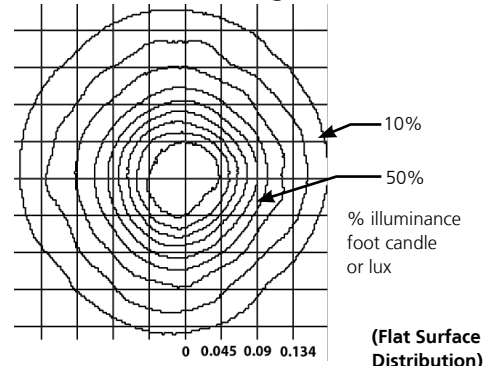

PHOTOMETRICS

Source 4WRD II PAR Gallery 90 CRI with NSP Lens

Mode	Degree	Candela	Lumens (Beam, Field)	Power Consumption	Lumens Per Watt
NSP	22.8	203,405	4,547, 9,162	149 W	61.5

Metric conversions: For meters, multiply feet by 0.3048  
For lux, multiply footcandles by 10.76

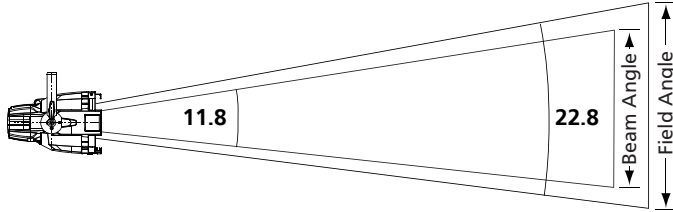

Throw Distance (d)	10 ft 3.0 m	15 ft 4.6 m	20 ft 6.1 m	25 ft 7.6 m	489.2 ft 149.1 m
Field Diameter	4.0 ft 1.2 m	6.0 ft 1.8 m	8.1 ft 2.5 m	10.1 ft 3.1 m	-
Illuminance (fc)	2,393	1,064	598	383	1
Illuminance (lux)	25,758	11,448	6,440	4,121	10.76

To determine center beam illumination in footcandles at any throw distance, divide candela by the throw distance squared

For field diameter at any distance, multiply distance by 0.403  
For beam diameter at any distance, multiply by 0.207

Source 4WRD II PAR Gallery 90 CRI with MFL Lens

Mode	Degree	Candela	Lumens (Beam, Field)	Power Consumption	Lumens Per Watt
MFL	35.5 Horizontal (H) 27.4 Vertical (V)	93,415	5,429, 9,205	149 W	61.8

Metric conversions: For meters, multiply feet by 0.3048  
For lux, multiply footcandles by 10.76

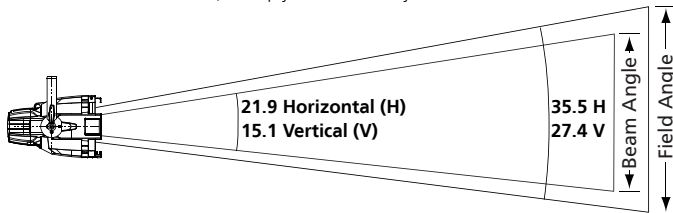

Throw Distance (d)	10 ft 3.0 m	15 ft 4.6 m	20 ft 6.1 m	25 ft 7.6 m	331.5 ft 101 m
Field Diameter	6.4 ft 2.0 m	9.6 ft 2.9 m	12.8 ft 3.9 m	16 ft 4.9 m	-
Illuminance (fc)	1,099	488	275	176	1
Illuminance (lux)	11,830	5,258	2,957	1,893	10.76

To determine center beam illumination in footcandles at any throw distance, divide candela by the throw distance squared

For field diameter at any distance, multiply distance by 0.640  
For field height at any distance, multiply distance by 0.488  
For beam diameter at any distance, multiply by 0.387  
For beam height at any distance, multiply by 0.265

Candela Plot

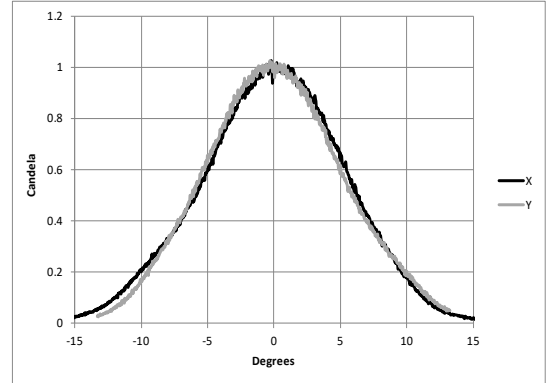

Iso-Illuminance Diagram

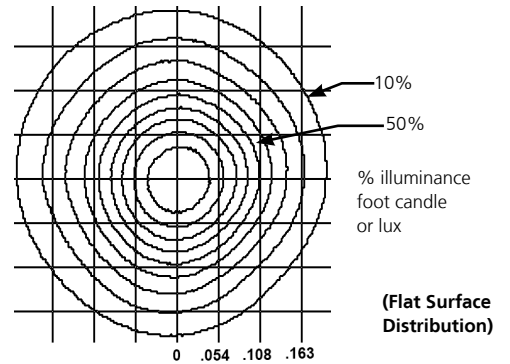

Candela Plot

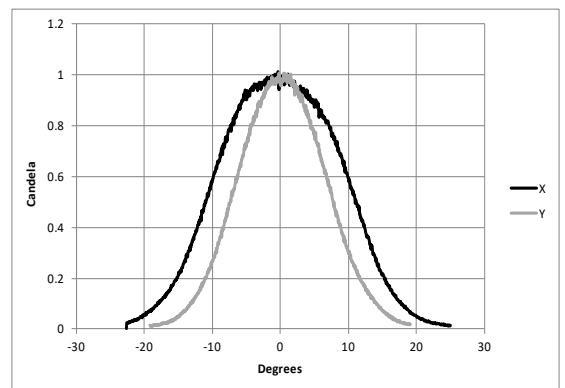

Iso-Illuminance Diagram

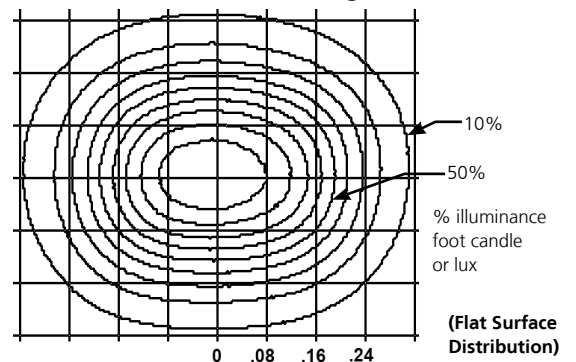

PHOTOMETRICS

Source 4WRD II PAR Gallery 90 CRI with WFL Lens

Mode	Degree	Candela	Lumens (Beam, Field)	Power Consumption	Lumens Per Watt
WFL	55.0 Horizontal (H) 40.0 Vertical (V)	35,105	5,571, 9,099	149 W	61.1

Metric conversions: For meters, multiply feet by 0.3048  
For lux, multiply footcandles by 10.76

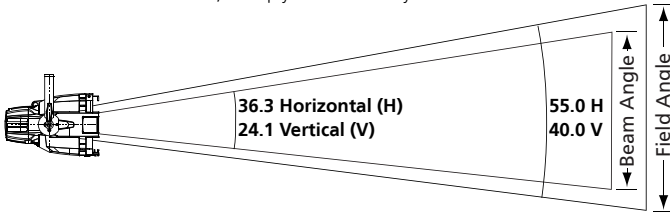

Throw Distance (d)	10 ft	15 ft	20 ft	25 ft	203.2 ft
	3.0 m	4.6 m	6.1 m	7.6 m	61.9 m
Field Diameter	10.4 ft	15.6 ft	20.8 ft	26.0 ft	-
	3.2 m	4.8 m	6.3 m	7.9 m	
Illuminance (fc)	413	184	103	66	1
Illuminance (lux)	4,445	1,976	1,111	711	10.76

To determine center beam illumination in footcandles at any throw distance, divide candela by the throw distance squared

For field diameter at any distance, multiply distance by 1.041  
For field height at any distance, multiply distance by 0.728  
For beam diameter at any distance, multiply by 0.656  
For beam height at any distance, multiply by 0.427

Candela Plot

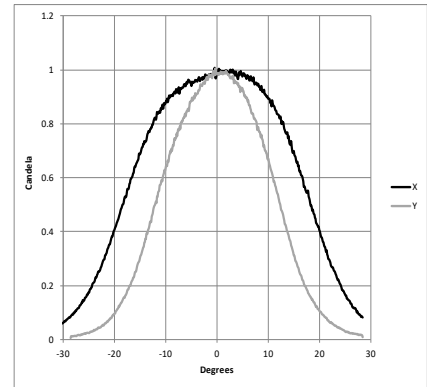

Iso-Illuminance Diagram

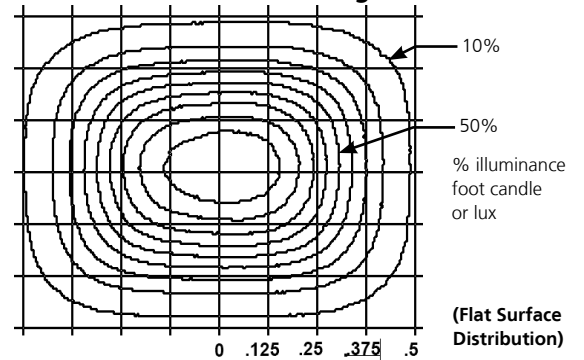

Source 4WRD II PAR Gallery 90 CRI with XWFL Lens

Mode	Degree	Candela	Lumens (Beam, Field)	Power Consumption	Lumens Per Watt
XWFL	62.5	21,165	2,581, 6,276	149 W	42.1

Metric conversions: For meters, multiply feet by 0.3048  
For lux, multiply footcandles by 10.76

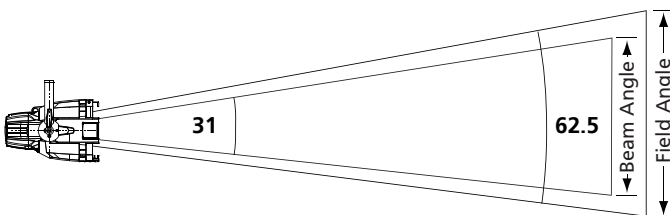

Throw Distance (d)	10 ft	15 ft	20 ft	25 ft	157.8 ft
	3.0 m	4.6 m	6.1 m	7.6 m	48.1 m
Field Diameter	12.1ft	18.2 ft	24.3 ft	30.3 ft	-
	3.7m	5.5 m	7.4 m	9.2 m	
Illuminance (fc)	249	111	62	40	1
Illuminance (lux)	2,680	1,191	670	429	10.76

To determine center beam illumination in footcandles at any throw distance, divide candela by the throw distance squared

For field diameter at any distance, multiply distance by 1.214  
For beam diameter at any distance, multiply by 0.555

Candela Plot

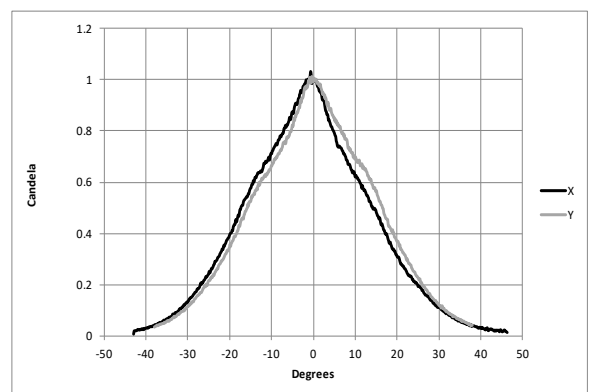

Iso-Illuminance Diagram

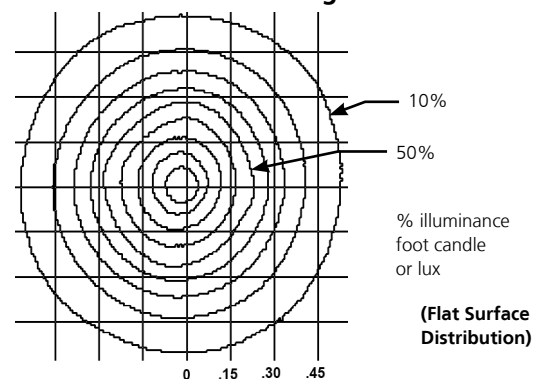

PHOTOMETRICS

Source 4WRD II PARNel Gallery 90 CRI Spot

Mode	Degree	Candela	Lumens (Beam, Field)	Power Consumption	Lumens Per Watt
PARNel 90 CRI Spot	25.5	148,725	4,003, 7,997	149 W	53.7

Metric conversions: For meters, multiply feet by 0.3048  
For lux, multiply footcandles by 10.76

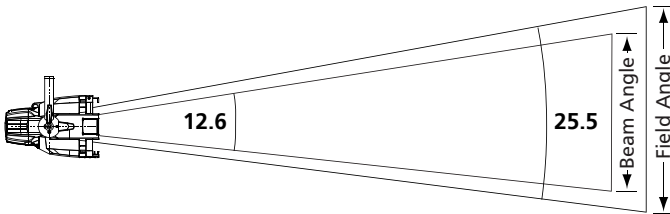

Throw Distance (d)	10 ft 3.0 m	15 ft 4.6 m	20 ft 6.1 m	25 ft 7.6 m	418.3 ft 127.5 m
Field Diameter	4.5 ft 1.4 m	6.8 ft 2.1 m	9.1 ft 2.8 m	11.3 ft 3.4 m	-
Illuminance (fc)	1,750	778	437	280	1
Illuminance (lux)	18,835	8,371	4,709	3,014	10.76

To determine center beam illumination in footcandles at any throw distance, divide candela by the throw distance squared

For field diameter at any distance, multiply distance by 0.453  
For beam diameter at any distance, multiply by 0.221

Source 4WRD II PARNel Gallery 90 CRI Flood

Mode	Degree	Candela	Lumens (Beam, Field)	Power Consumption	Lumens Per Watt
PARNel 90 CRI Flood	43.8	42,467	5,850, 9,094	149 W	61.0

Metric conversions: For meters, multiply feet by 0.3048  
For lux, multiply footcandles by 10.76

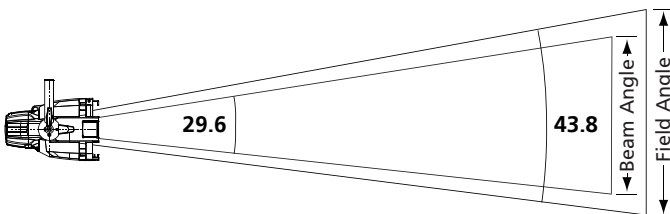

Throw Distance (d)	10 ft 3.0 m	15 ft 4.6 m	20 ft 6.1 m	25 ft 7.6 m	222.4 ft 67.8 m
Field Diameter	8.0 ft 2.5 m	12.1 ft 3.7 m	16.1 ft 4.9 m	20.1 ft 6.1 m	-
Illuminance (fc)	495	220	124	79	1
Illuminance (lux)	5,323	2,366	1,331	852	10.76

To determine center beam illumination in footcandles at any throw distance, divide candela by the throw distance squared

For field diameter at any distance, multiply distance by 0.804  
For beam diameter at any distance, multiply by 0.528

Candela Plot

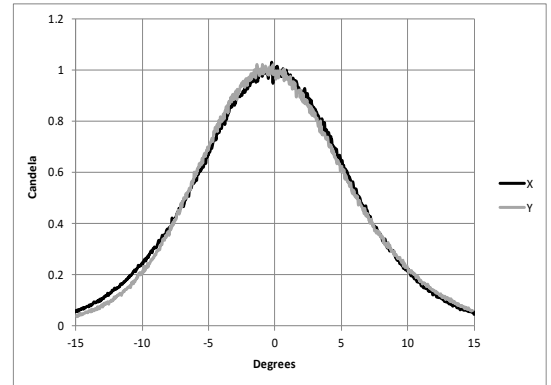

Iso-Illuminance Diagram

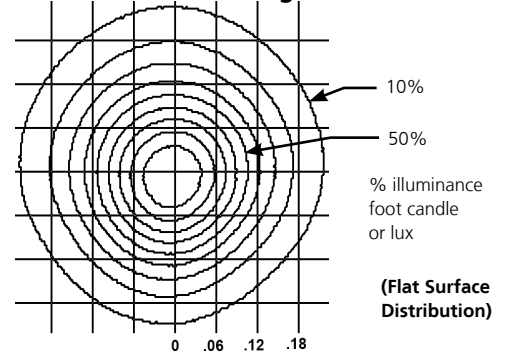

Candela Plot

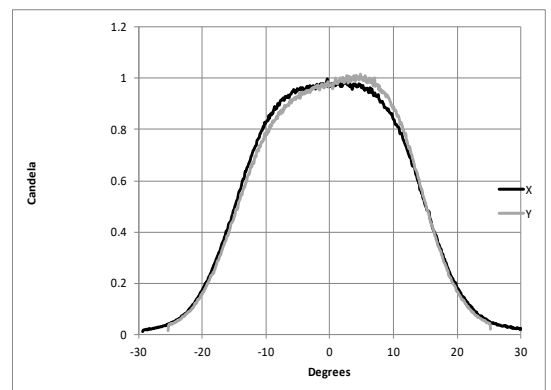

Iso-Illuminance Diagram

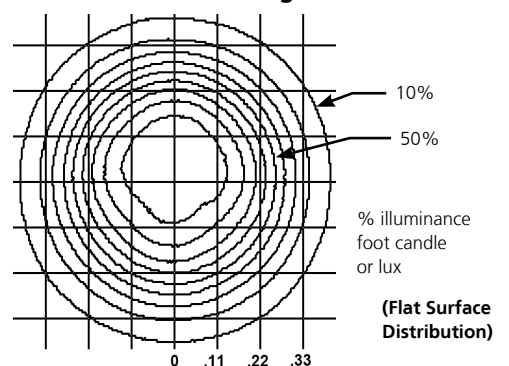



PHOTOMETRICS

Source 4WRD II PAR Daylight Gallery 90 CRI with AR Coated Flat Lens

Mode	Degree	Candela	Lumens (Beam, Field)	Power Consumption	Lumens Per Watt
AR Coated Flat	20.3	266,146	4,940, 10,248	152 W	67.4

Metric conversions: For meters, multiply feet by 0.3048  
For lux, multiply footcandles by 10.76

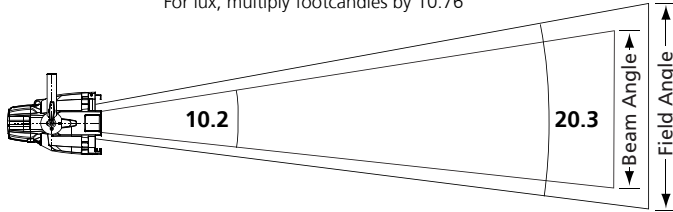

Throw Distance (d)	10 ft	15 ft	20 ft	25 ft	569 ft
	3.0 m	4.6 m	6.1 m	7.6 m	173.4 m
Field Diameter	3.6 ft	5.4 ft	7.2 ft	9.0 ft	-
	1.1 m	1.6 m	2.2 m	2.7 m	-
Illuminance (fc)	3,238	1,439	810	518	1
Illuminance (lux)	34,854	15,491	8,714	5,577	10.76

To determine center beam illumination in footcandles at any throw distance, divide candela by the throw distance squared

For field diameter at any distance, multiply distance by 0.358  
For beam diameter at any distance, multiply by 0.178

Source 4WRD II PAR Daylight Gallery 90 CRI with VNSP Lens

Mode	Degree	Candela	Lumens (Beam, Field)	Power Consumption	Lumens Per Watt
VNSP	21.7	254,295	4,620, 9,888	152 W	65.1

Metric conversions: For meters, multiply feet by 0.3048  
For lux, multiply footcandles by 10.76

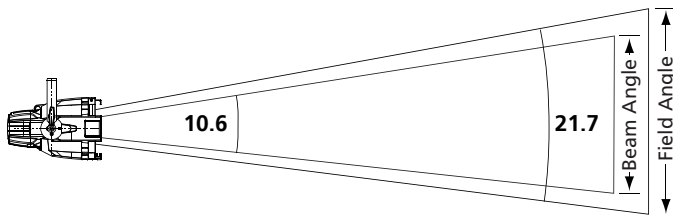

Throw Distance (d)	10 ft	15 ft	20 ft	25 ft	530.4 ft
	3.0 m	4.6 m	6.1 m	7.6 m	161.7 m
Field Diameter	3.8 ft	5.7 ft	7.7 ft	9.6 ft	-
	1.2 m	1.8 m	2.3 m	2.9 m	-
Illuminance (fc)	2,813	1,250	703	450	1
Illuminance (lux)	30,279	13,457	7,570	4,845	10.76

To determine center beam illumination in footcandles at any throw distance, divide candela by the throw distance squared

For field diameter at any distance, multiply distance by 0.383  
For beam diameter at any distance, multiply by 0.186

Candela Plot

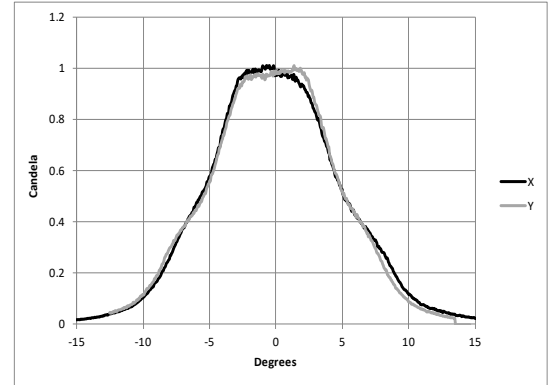

Iso-Illuminance Diagram

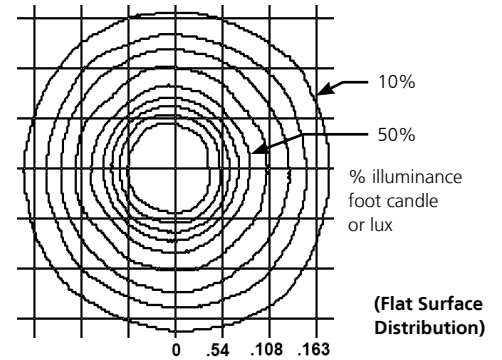

Candela Plot

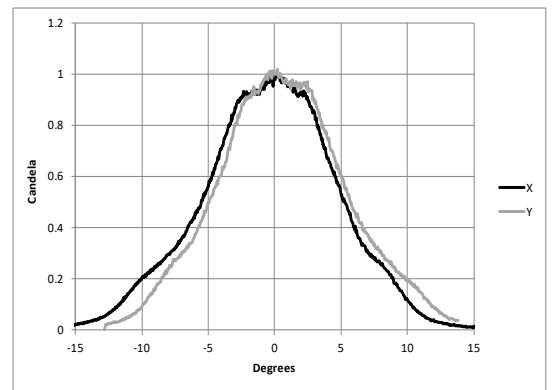

Iso-Illuminance Diagram

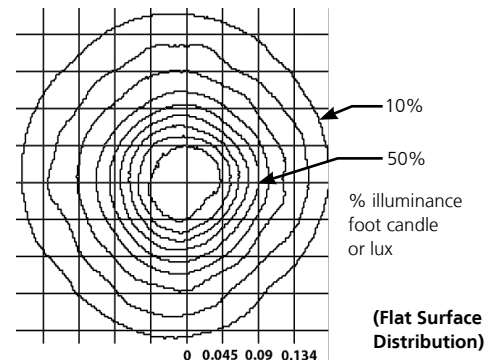

PHOTOMETRICS

Source 4WRD II PAR Daylight Gallery 90 CRI with NSP Lens

Mode	Degree	Candela	Lumens (Beam, Field)	Power Consumption	Lumens Per Watt
NSP	22.8	216,327	4,835, 9,744	152 W	64.1

Metric conversions: For meters, multiply feet by 0.3048  
For lux, multiply footcandles by 10.76

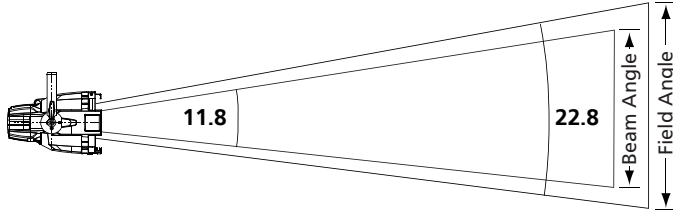

Throw Distance (d)	10 ft	15 ft	20 ft	25 ft	489.2 ft
	3.0 m	4.6 m	6.1 m	7.6 m	149.1 m
Field Diameter	4.0 ft	6.0 ft	8.1 ft	10.1 ft	-
	1.2 m	1.8 m	2.5 m	3.1 m	-
Illuminance (fc)	2,393	1,064	598	383	1
Illuminance (lux)	25,758	11,448	6,440	4,121	10.76

To determine center beam illumination in footcandles at any throw distance, divide candela by the throw distance squared

For field diameter at any distance, multiply distance by 0.403  
For beam diameter at any distance, multiply by 0.207

Source 4WRD II PAR Daylight Gallery 90 CRI with MFL Lens

Mode	Degree	Candela	Lumens (Beam, Field)	Power Consumption	Lumens Per Watt
MFL	35.5 Horizontal (H) 27.4 Vertical (V)	99,350	5,774, 9,789	152 W	64.4

Metric conversions: For meters, multiply feet by 0.3048  
For lux, multiply footcandles by 10.76

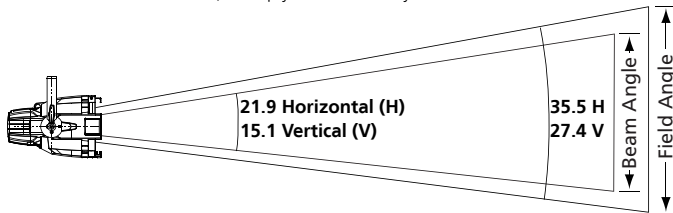

Throw Distance (d)	10 ft	15 ft	20 ft	25 ft	331.5 ft
	3.0 m	4.6 m	6.1 m	7.6 m	101 m
Field Diameter	6.4 ft	9.6 ft	12.8 ft	16 ft	-
	2.0 m	2.9 m	3.9 m	4.9 m	-
Illuminance (fc)	1,099	488	275	176	1
Illuminance (lux)	11,830	5,258	2,957	1,893	10.76

To determine center beam illumination in footcandles at any throw distance, divide candela by the throw distance squared

For field diameter at any distance, multiply distance by 0.640  
For field height at any distance, multiply distance by 0.488  
For beam diameter at any distance, multiply by 0.387  
For beam height at any distance, multiply by 0.265

Candela Plot

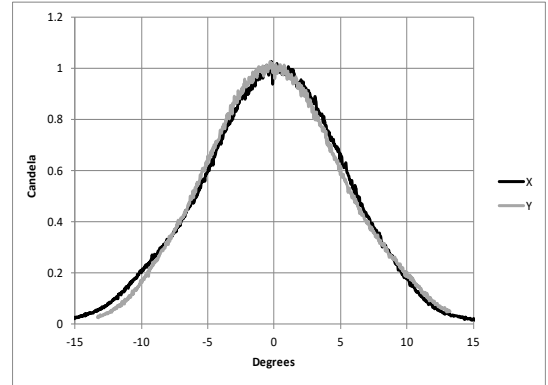

Iso-Illuminance Diagram

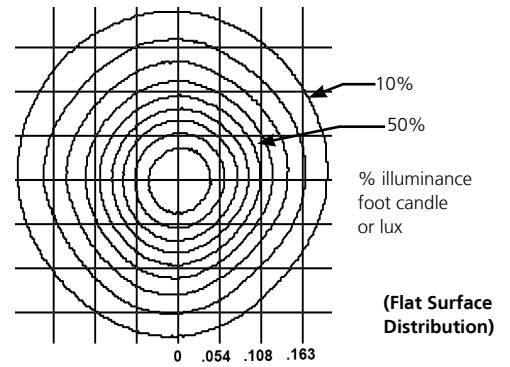

Candela Plot

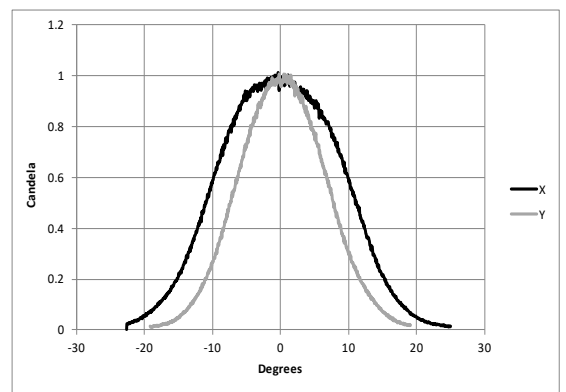

Iso-Illuminance Diagram

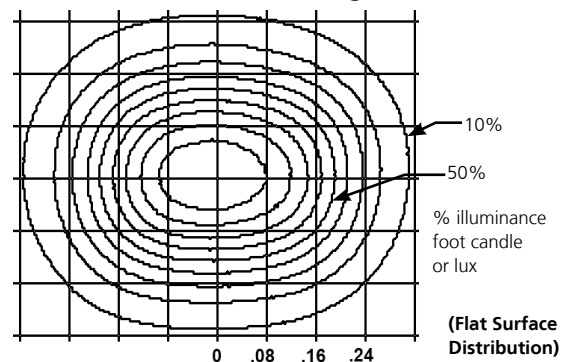

PHOTOMETRICS

Source 4WRD II PAR Daylight Gallery 90 CRI with WFL Lens

Mode	Degree	Candela	Lumens (Beam, Field)	Power Consumption	Lumens Per Watt
WFL	55.0 Horizontal (H) 40.0 Vertical (V)	37,335	5,925, 9,677	152 W	63.7

Metric conversions: For meters, multiply feet by 0.3048  
For lux, multiply footcandles by 10.76

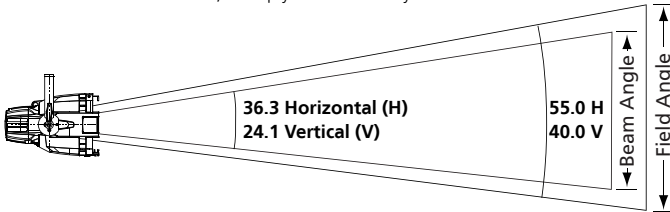

Throw Distance (d)	10 ft	15 ft	20 ft	25 ft	203.2 ft
	3.0 m	4.6 m	6.1 m	7.6 m	61.9 m
Field Diameter	10.4 ft	15.6 ft	20.8 ft	26.0 ft	-
	3.2 m	4.8 m	6.3 m	7.9 m	-
Illuminance (fc)	413	184	103	66	1
Illuminance (lux)	4,445	1,976	1,111	711	10.76

To determine center beam illumination in footcandles at any throw distance, divide candela by the throw distance squared

For field diameter at any distance, multiply distance by 1.041  
For field height at any distance, multiply distance by 0.728  
For beam diameter at any distance, multiply by 0.656  
For beam height at any distance, multiply by 0.427

Candela Plot

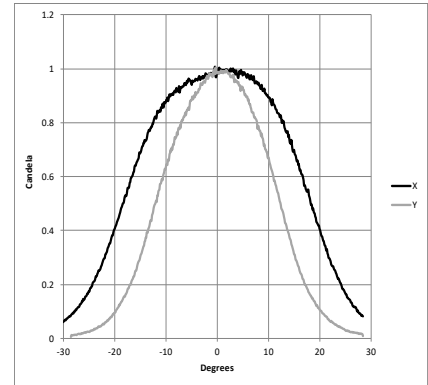

Iso-Illuminance Diagram

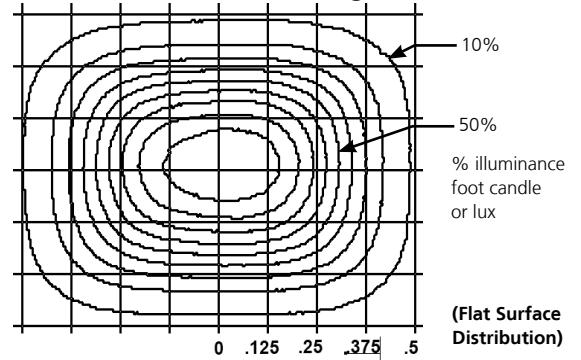

Source 4WRD PAR Daylight Gallery 90 CRI with XWFL Lens

Mode	Degree	Candela	Lumens (Beam, Field)	Power Consumption	Lumens Per Watt
XWFL	62.5	22,510	2,745, 6,675	152 W	43.9

Metric conversions: For meters, multiply feet by 0.3048  
For lux, multiply footcandles by 10.76

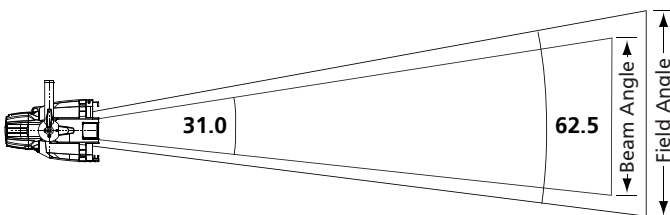

Throw Distance (d)	10 ft	15 ft	20 ft	25 ft	157.8 ft
	3.0 m	4.6 m	6.1 m	7.6 m	48.1 m
Field Diameter	12.1ft	18.2 ft	24.3 ft	30.3 ft	-
	3.7m	5.5 m	7.4 m	9.2 m	-
Illuminance (fc)	249	111	62	40	1
Illuminance (lux)	2,680	1,191	670	429	10.76

To determine center beam illumination in footcandles at any throw distance, divide candela by the throw distance squared

For field diameter at any distance, multiply distance by 1.214  
For beam diameter at any distance, multiply by 0.555

Candela Plot

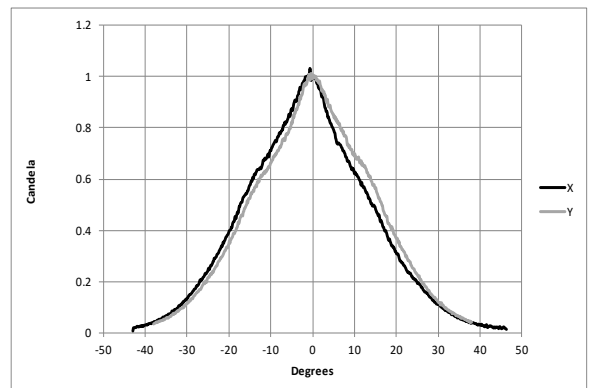

Iso-Illuminance Diagram

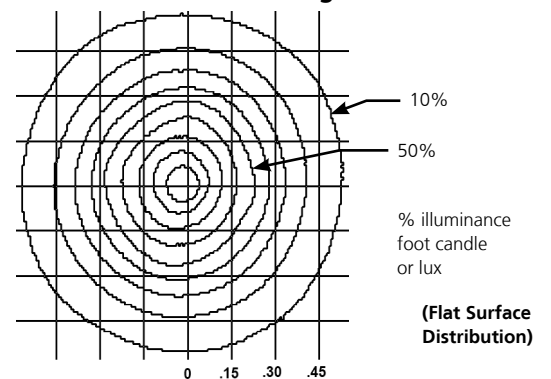

PHOTOMETRICS

Source 4WRD II PARNel Daylight Gallery 90 CRI Spot

Mode	Degree	Candela	Lumens (Beam, Field)	Power Consumption	Lumens Per Watt
PARNel 90 CRI Spot	25.5	153,655	4,255, 8,460	152 W	55.7

Metric conversions: For meters, multiply feet by 0.3048  
For lux, multiply footcandles by 10.76

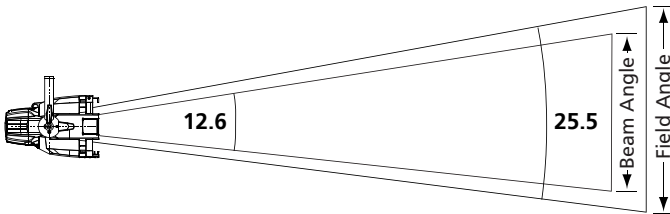

Throw Distance (d)	10 ft 3.0 m	15 ft 4.6 m	20 ft 6.1 m	25 ft 7.6 m	418.3 ft 127.5 m
Field Diameter	4.5 ft 1.4 m	6.8 ft 2.1 m	9.1 ft 2.8 m	11.3 ft 3.4 m	-
Illuminance (fc)	1,750	778	437	280	1
Illuminance (lux)	18,835	8,371	4,709	3,014	10.76

To determine center beam illumination in footcandles at any throw distance, divide candela by the throw distance squared

For field diameter at any distance, multiply distance by 0.453  
For beam diameter at any distance, multiply by 0.221

Source 4WRD II PARNel Daylight Gallery 90 CRI Flood

Mode	Degree	Candela	Lumens (Beam, Field)	Power Consumption	Lumens Per Watt
PARNel 90 CRI Flood	43.8	45,237	6,078, 9,670	152 W	63.6

Metric conversions: For meters, multiply feet by 0.3048  
For lux, multiply footcandles by 10.76

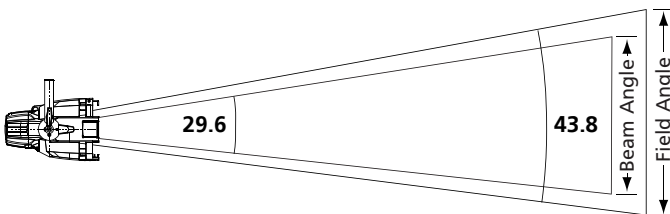

Throw Distance (d)	10 ft 3.0 m	15 ft 4.6 m	20 ft 6.1 m	25 ft 7.6 m	222.4 ft 67.8 m
Field Diameter	8.0 ft 2.5 m	12.1 ft 3.7 m	16.1 ft 4.9 m	20.1 ft 6.1 m	-
Illuminance (fc)	495	220	124	79	1
Illuminance (lux)	5,323	2,366	1,331	852	10.76

To determine center beam illumination in footcandles at any throw distance, divide candela by the throw distance squared

For field diameter at any distance, multiply distance by 0.804  
For beam diameter at any distance, multiply by 0.528

Candela Plot

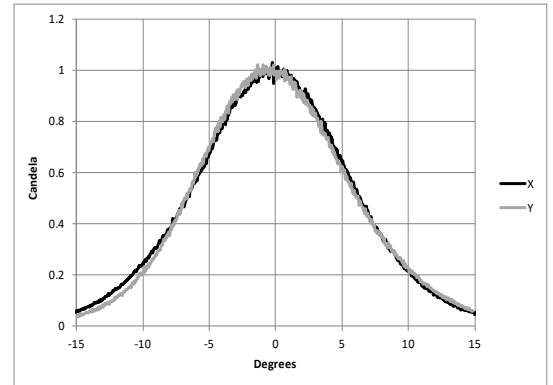

Iso-Illuminance Diagram

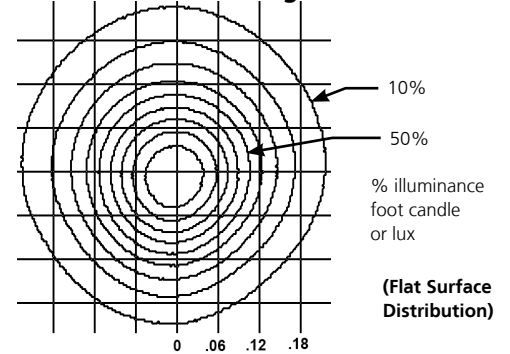

Candela Plot

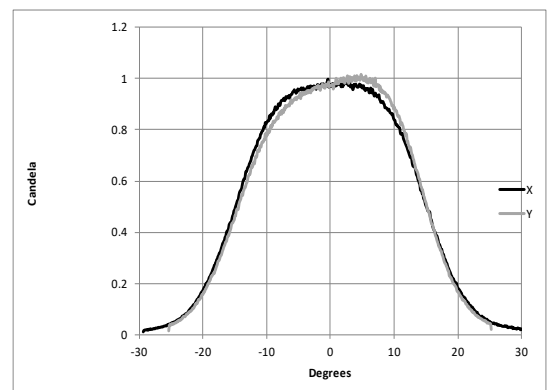

Iso-Illuminance Diagram

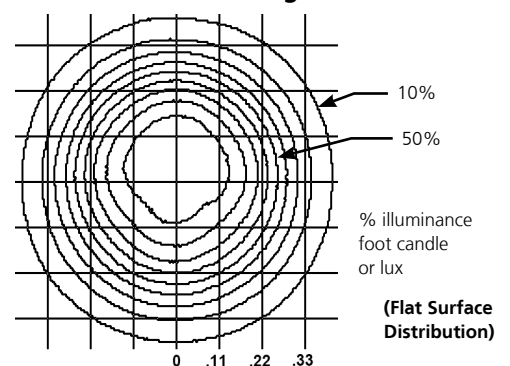

PHYSICAL

Dimensions

MODEL	HEIGHT		WIDTH		DEPTH	
	in	mm	in	mm	in	mm
4WRD PAR	11.04	280	10.63	270	12.79	325
4WRD PARNeI	11.68	296	10.63	270	12.79	325

Weights

MODEL	WEIGHT*		SHIPPING WEIGHT		WEIGHT WITH S4WRD II LED*	
	lb	kg	lb	kg	lb	kg
4WRD PAR	6.25	2.83	8.20	3.72	9.95	4.51
4WRD PARNeI	7.70	3.49	9.65	4.34	11.40	5.17

\*Without mounting hardware

SOURCE 4WRD PAR (WITH SOURCE 4WRD II LED)

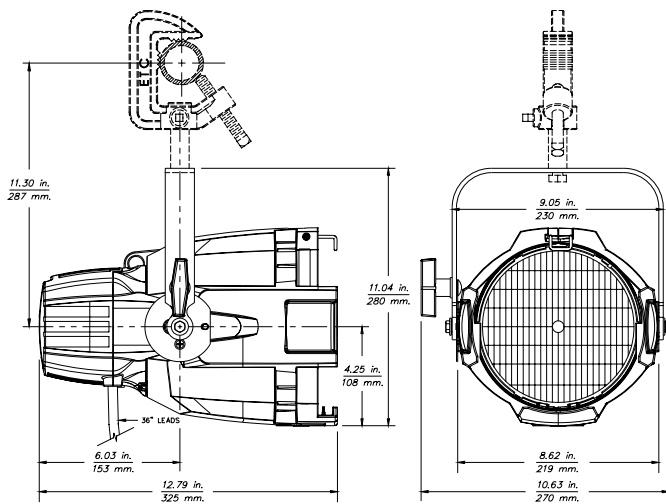

SOURCE 4WRD PARNeI (WITH SOURCE 4WRD II LED)

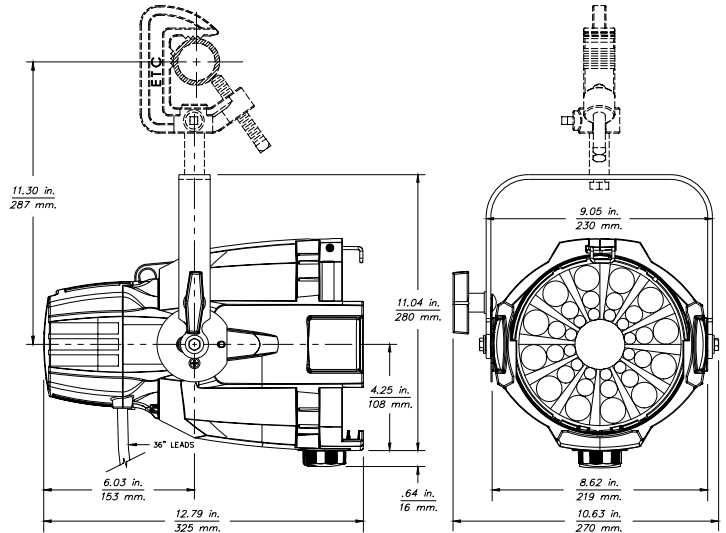

SOURCE 4WRD PAR (BODY ONLY)

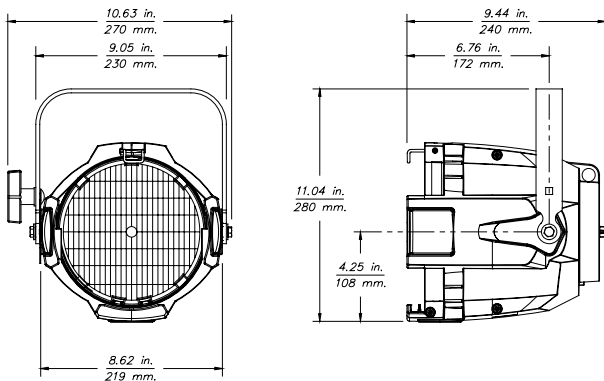

SOURCE 4WRD PARNeI (BODY ONLY)

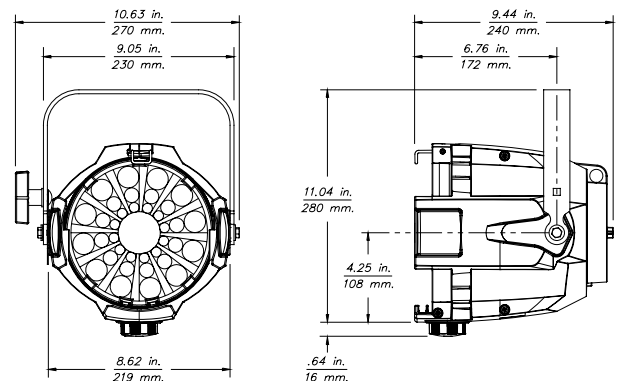

Corporate Headquarters • Middleton, WI USA  
 Global Offices • London, UK • Rome, IT • Holzkirchen, DE • Paris, FR • Hong Kong  
 Dubai, UAE • Singapore • New York, NY • Orlando, FL • Los Angeles, CA • Austin, TX  
 Copyright©2021 ETC. All Rights Reserved. All product information and specifications subject to change. Rev H 2021-10  
 \*Trademark and patent info: [etconnect.com/IE](http://etconnect.com/IE)

etconnect.com